

EK-TRON 5.300 G-R F3 (72H)  
 EK-TRON 6.350 G-R F3 (72H)  
 EK-TRON 6.400 G-R F3 (72H)  
 EK-TRON 7.500 G-R F3 (72H)  
 EK-TRON 7.600 G-R F3 (72H)

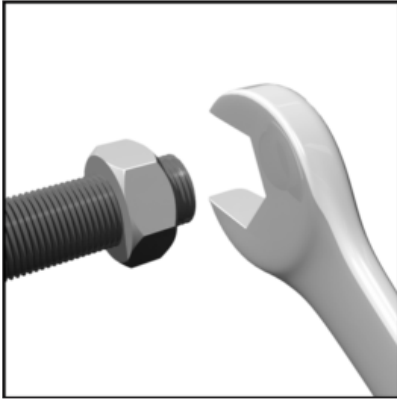

en



**Original operating instructions**  
 For specialist installation engineers  
**Gas burners**



cn..... 420011248700

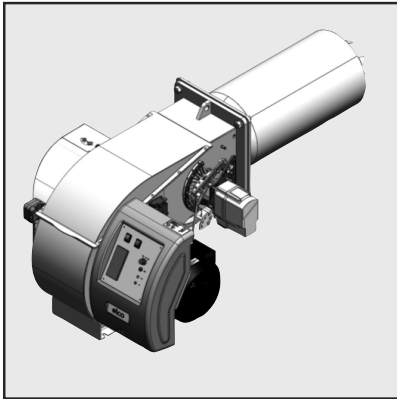

EK-TRON 5-6-7.xxx G-R F3 420011248800

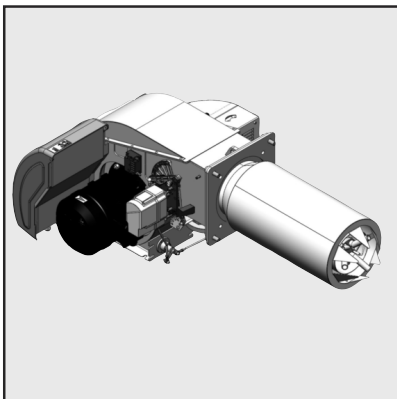

EK-TRON 5-6-7.xxx G-R F3 420011xxxx

EK-TRON 5.300 G-R F3 KM	3148297
EK-TRON 5.300 G-R F3 KL	3148298
EK-TRON 6.350 G-R F3 KM	3148427
EK-TRON 6.350 G-R F3 KL	3148428
EK-TRON 6.400 G-R F3 KM	3148299
EK-TRON 6.400 G-R F3 KL	3148300
EK-TRON 7.500 G-R F3 KM	3148301
EK-TRON 7.500 G-R F3 KL	3148302
EK-TRON 7.600 G-R F3 KM	3148303
EK-TRON 7.600 G-R F3 KL	3148304
EK-TRON 5.300 G-R F3 KM 72H	3148462
EK-TRON 5.300 G-R F3 KL 72H	3148463
EK-TRON 6.350 G-R F3 KM 72H	3148464
EK-TRON 6.350 G-R F3 KL 72H	3148465
EK-TRON 6.400 G-R F3 KM 72H	3148466
EK-TRON 6.400 G-R F3 KL 72H	3148467
EK-TRON 7.500 G-R F3 KM 72H	3148468
EK-TRON 7.500 G-R F3 KL 72H	3148469
EK-TRON 7.600 G-R F3 KM 72H	3148470
EK-TRON 7.600 G-R F3 KL 72H	3148471



# General information

## Contents

---

	Page
<b>General information</b>	
Contents	.2
Important information	.3
Burner description	.4-6
<b>Installation</b>	
General information regarding burner installation	.5
Boiler lining	.6
Burner installation	.7
Combustion components	
Combustion components EK-TRON 5.300 - 6.400 G-R adjustment data/check	.8
Combustion components EK-TRON 7.5-600 G-R adjustment data/check	.9
Ignition electrodes adjustment data/check	.10
Gas train	
Description of gas train with VGD	.11
Description of gas train with MBE	.12
Basic design	.13
Description of double gas valve VGD with SKP servomotors	.14
<b>Gas train components</b>	
Gas filter	.15
Gas pressure switch	.16
Air pressure switch	.17
<b>Commissioning</b>	
Electronic burner controller	
Description	.18
Electronic burner controller display	.19
Display	.20
Servomotor	.21
First startup with a new program module or in case of replacement of program module	.22
Manual backup	.23
Manual restore	.24
Switch cabinet door layout	.25
Servomotor SQM4x.xxx	.26
Flame sensor	.27
Gas fitting connection, electrical connection, checks before commissioning	.28
Gas connection	.29
Fuel-air compound controller	.30
Burner power adjusting sequence	.31
Inspection	.32
Preventilation	.33
Gas start-up mode	.34
Gas operating mode	.35
Setting	.35
General safety functions	.36
<b>Servicing</b>	
Maintenance	.37-39
Maintenance, Checking / installing the combustion components	.40
Fan wheel setting	.41
Exhaust gas measurement	.42
Diagnosing and remedying faults	.43
Faults	.44
Troubleshooting instructions	.45

# General information

## Important information

### Important information

The EK-TRON 5/6/7.xxx G-R burners are designed for burning natural gas. The design and function of the burners comply with standard EN676. They are intended for equipping systems that allow burners to be used in accordance with EN 676. Special burner components are required in order to use the burner on heat generators in accordance with the Pressure Equipment Directive 97/23/EC (not a constituent of the standard equipment). Before using the burner with equipment of this type, the equipment characteristics must be checked. Burners that comply with Pressure Equipment Directive 97/23/EU come with a declaration of conformity to this effect and are labelled on the identification plate. Any other type of application requires the approval of ELCO. The burner may only be used in accordance with the instructions set out in this documentation and the relevant technical data. If not used properly, it could cause damage to property and the environment and personal injury. Furthermore, the burner would no longer be CE-compliant. Installation, commissioning and maintenance must only be carried out by authorised specialists and, during these operations, all applicable directives and regulations must be complied with. The burners designed to run on propane do not currently have any CE approval and therefore require individual on-site approval.

### Burner description

Burners EK-TRON 5/6/7.xxx G-R are mechanical modulating, fully automatic monoblock burners. The special design of the burner head provides highly efficient, lowpolluting combustion. In accordance with the certification as per EN676 (versions in natural gas mode only), the values obtained must respect emission class. Emissions rates may differ, depending on combustion chamber geometry, combustion chamber load and the firing system (three-pass boilers, boilers with reverse firing). For specifying warranty values, the conditions for the measuring equipment, tolerances and humidity must be observed.

### Scope of delivery

The burner is supplied in one packaging units:

- Burner with:
- integrated switch cabinet
- flange seal and securing screws
- burner head
- operating instructions, circuit diagram and spare parts list.

Before commissioning, a check must be carried out to ensure that the product delivered fully complies with the scope of delivery.

The following standards should be observed in order to ensure safe, environmentally sound and energy efficient operation:

### EN 226

Connection of atomising oil and gas burners with fan to the heat generator.

### EN 60335-1, -2-102

Safety of electrical equipment for domestic use.

### DIN EN 60204-1

Safety of machinery. Electrical equipment of machines.

### DIN EN 50156-1

Electrical equipment for firing systems

### Gas lines

When routing gas lines and trains, observe the general installation regulations and directives as well as national guidelines:

- CH: - SVGW gas directives G1.  
- EKAS Form.1942 Liquefied Petroleum Gas- directive, part 2.  
- Regulations on cantonal instances (e.g. fire department regulations).  
DE: - DVGW-TRV/TRGI

### Installation location

The burner must not be operated in rooms with aggressive vapours (e.g. hair spray, tetrachlorethylene, carbon tetrachloride), high levels of dust or high air humidity (e.g. laundry rooms). The limitations of use set out in the technical data must be observed.

Adequate provision must be made for the supply of combustion air. Given standard conditions, the combustion air requirement may be calculated as follows:  
 $VI [Nm^3/h] = QF [kW] * 1.25 [Nm^3/(h * kW)]$

### We can accept no warranty for loss, damage or injury caused by any of the following reasons:

- Inappropriate use
- incorrect installation and/or repair on the part of the buyer or any third party, including the fitting of non-original parts.

### Final delivery and instructions for use

The firing system fitter must supply the operator of the system with operating and maintenance instructions on or before final delivery. These instructions should be displayed in a prominent location at the point of installation of the heat generator. They should include the address and telephone number of the nearest customer service centre.

### Notes for the operator

The system should be inspected by a specialist at least once a year. It is strongly recommended to take out a service contract to guarantee regular servicing.

### Please note:

When in operation, the burner produces an electromagnetic field. In certain circumstances, this field could affect medical implants (e.g. pacemakers). Before working with the machine, anyone who has a medical implant should consult their doctor and the manufacturer of the medical implant in order to reduce the risk of serious or fatal injury.

### Attention:

During operation the burners produce an electromagnetic field that may, under certain  
09/09/2022 - Art. Nr. 420011248600

circumstances, cause medical implants (e.g. pacemakers) to deteriorate. In order to minimise any risk of serious or fatal injury, anyone who has a medical implant should seek medical advice and ask the implant manufacturer before approaching their workplace.

### Transport \ packaging \ storage

#### Safety measures

The burner and accessories must be transported and stored using suitable lifting equipment, means of transport and tools. The safety instructions must be complied with.

#### Transportation

Depending on the size and weight of packaging, burners and accessories must be transported manually or with the use of suitable aids. The transport instructions on the packaging must be complied with. The burner must be properly secured for transport. If measures to secure the burner have not been taken at the factory, suitable measures to secure it during transportation must be taken.

#### Packaging

The burner and accessories are packed on a wooden pallet and shrink-wrapped. When unpacking the product, suitable lifting equipment and tools must be used to remove the screw connections and clamping devices between the burner and the packaging. Suitable protective clothing must be worn (gloves, safety shoes).

#### Storage

In order to protect the burner from environmental influences, it must be placed in a dry, locked room when stored temporarily. For the maximum storage temperatures, please refer to the technical data sheet.

#### Disposal

Local and currently applicable legislation must always be observed.



en

## General information

### EK-TRON 6.400 G-R F3 Burner description

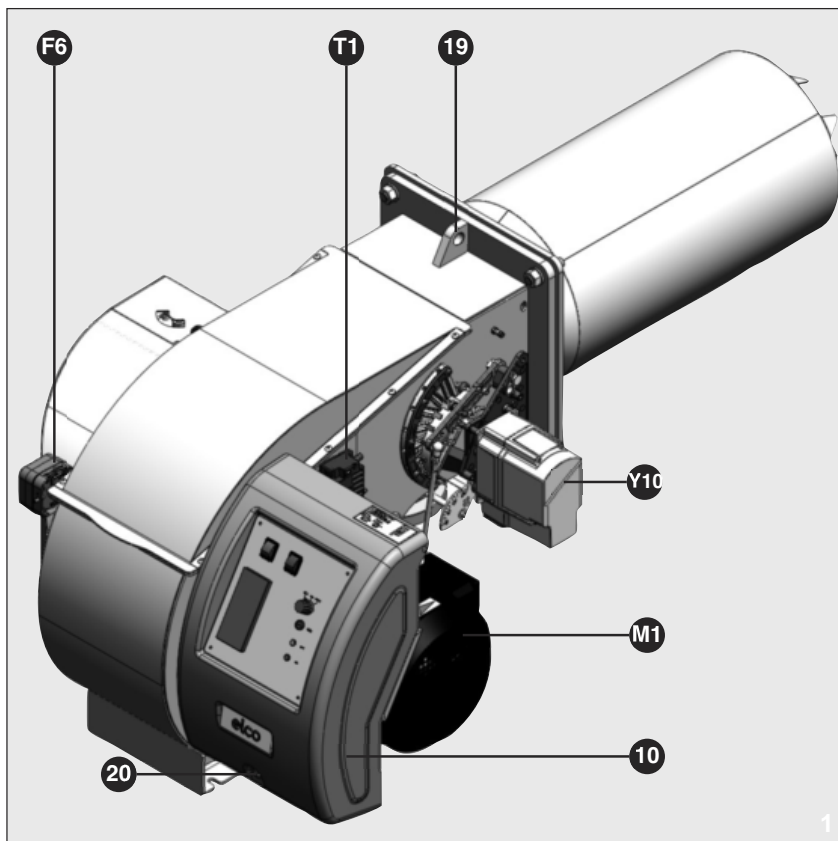

- 5 Casing
- 8 Blast tube
- 10 Integrated switch cabinet
- 11 Burner flange
- 13 Air box
- 19 Hoisting rings
- 20 Fastening screw/cover of switch cabinet
- F6 Air pressure switch
- M1 Electric motor
- T1 Igniter
- Y10 Servomotor for air and/or gas flaps

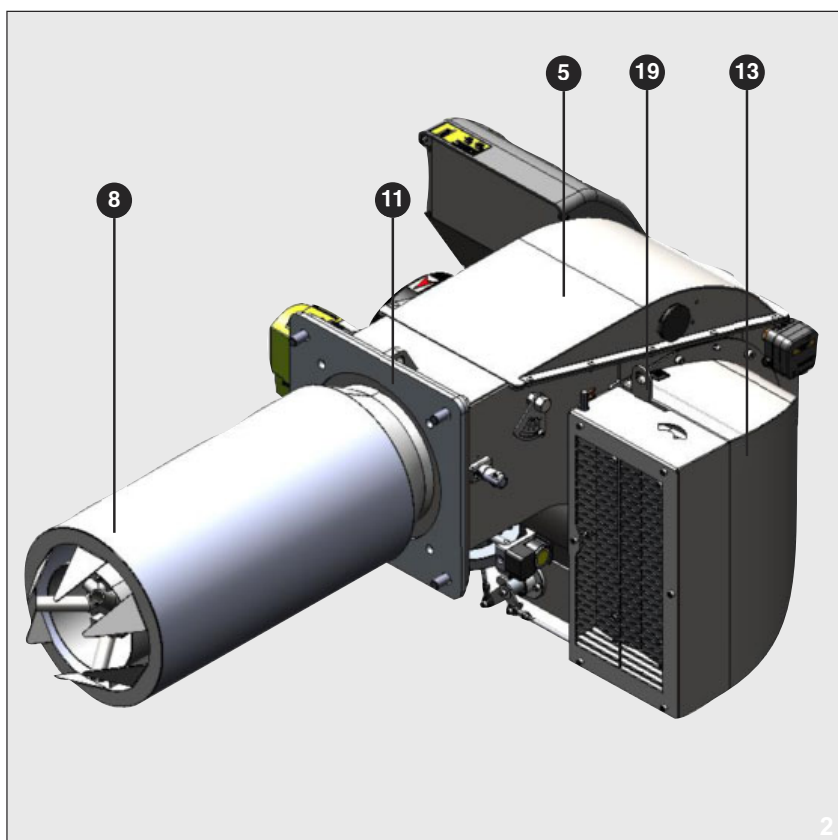

# General information

## General information regarding burner installation

### Tightening torques

During installation, commissioning and maintenance, the following torques for screw connections must be observed.

Max. tightening torques for accessories system, double gas valve								
	M4	M5	M6	M8	G1/8	G1/4	G1/2	G3/4
<b>Siemens</b>	3 Nm	-	7 Nm	15 Nm	8 Nm	15 Nm	-	35 Nm
<b>Dungs</b>	2,5 Nm	5 Nm			5 Nm	7 Nm	10 Nm	15 Nm

**N.B.:**  
In general, the correct tightening torques have been applied when the unions are tightened hand-tight using a screwdriver (ISO 272) or angled Allen key.

Recommended tightening torques Standard unions								
M4	M5	M6	M8	M10	M12	M16	M20	
2	6	10	25	48	85	210	415	Nm

**N.B.:**  
In general, the correct tightening torques have been applied when the unions are tightened hand-tight using a screwdriver (ISO 272) or angled Allen key.

Tightening torques of electrical connections for bolts on terminal boards								
M4	M5	M6	M8	M10				
1.2	2	3	6	10				Nm

**N.B.:**  
Check the tightness of electrical connections before using the burner. Make sure to observe the tightening torques listed above!  
**WARNING:**  
Electrical shock hazard!  
There is a risk of coming into contact with live parts! This could lead to fatal electrical shock!  
The motor must be switched off via an omnipolar cut-off switch and protected against accidental reconnection.

Tightening torques for root connector for fan impeller			
SM16 ( 28) No.: 1615	SM20 ( 38 and 42) No.: 2012	SM25 ( 42 and 48) No.: 2517	Bushing
20	30	50	Nm

**N.B.:**  
For more information regarding installation/dismantling of the fan impeller, please refer to the relevant chapter in the operating instructions.

Tightening torques flange connection solenoid valves and gas filter	
M16 / DN 65 - DN 125	M20 / DN 150
max. 50 Nm	max. 90 Nm

**N.B.:**  
The unions must be tightened crosswise. The union must be checked to ensure it is tight. If it is not sufficiently tight, the valve must be removed and checked (tightening surfaces).

en

# Installation

## Boiler lining

### Boiler lining

The burner lining must be installed at a right angle to the burner tube. Possible trimming work (bevelling, rounding) as required for reverse boilers, for example, should be done at a diameter not below 70% of the combustion chamber diameter. The space between the flame tube of the burner and the boiler lining should be lined with heat resistant material, such as Cerafelt.

**This space must not be lined with brickwork.**

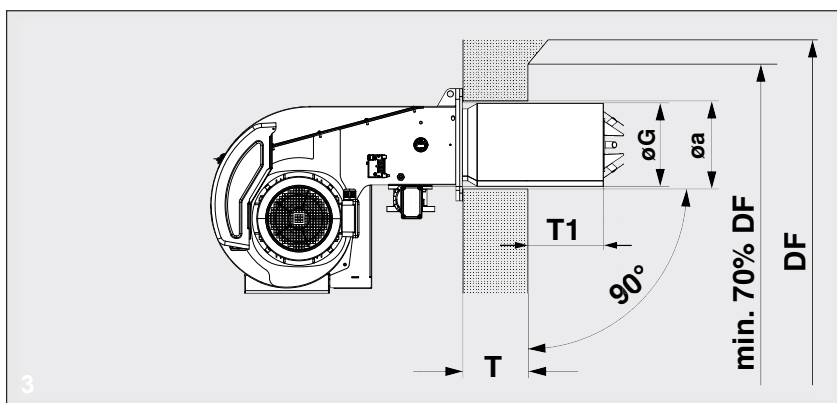

$\varnothing G$  = blast tube diameter  
(see technical data).  
 $\varnothing a$  = see technical data  
 $DF$  = combustion chamber diameter  
 $T1$ :

Model	T1(mm)
EK-TRON 5.300 G-R F3	> 150-250
EK-TRON 6.350 G-R F3	> 150-250
EK-TRON 6.400 G-R F3	> 150-250
EK-TRON 7.500 G-R F3	> 150-250
EK-TRON 7.600 G-R F3	> 150-250

$T$  = standard muffler depth  
(option: extensions: see technical data).

**Please note for reverse flow boilers:**  
For reverse flow boilers, dimension  $T1$  is only a recommended value. Depending on the type of boiler, the combustion head must project at least beyond the reversal gap by the dimension below.

# Installation

## Burner installation

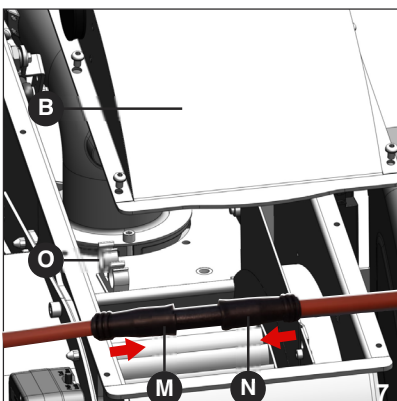
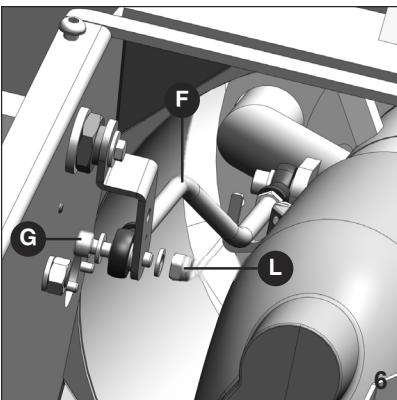
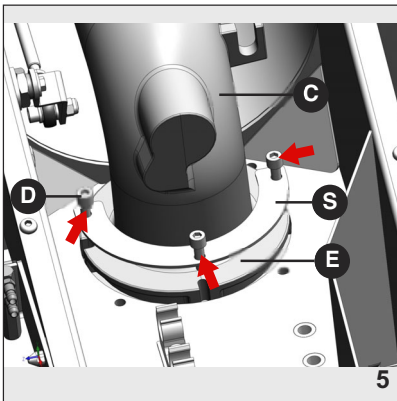
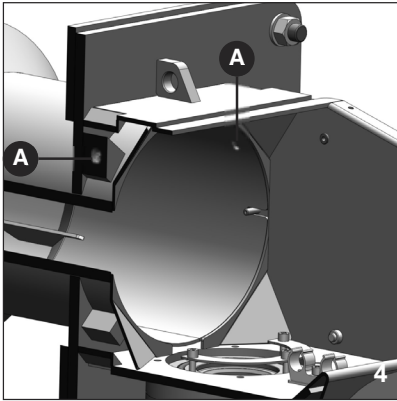

### Assembly of the combustion head

The burner is supplied in the package with the combustion head dismantled. Before fastening it to the boiler, perform the following operations:

- Fasten the nosepiece in the correct position using the 2 screws **A** (fig.4).
- Remove the cover **B** and fasten the combustion head **C** using the 3 screws **D** (tightening torque 10+12 Nm) already present in the burner, while making sure that seal **E** (fig.5) is correctly positioned. Only for the models 5.300 interpose the plate steel **S** between the elbow and the screws.
- Connect the head adjuster rod **F** to pin **G** by tightening the nut **L** (tightening torque 6+8 Nm) (fig.6).
- Connect the two connectors **M** and **N** of the ignition cable and fasten it to support **O** of the burner (fig.7).
- Put cover **B** back on by tightening the relative screws (tightening torque 6+8 Nm).

### Burner installation

- Attach boiler front gasket to the burner (see section entitled Burner front gasket).
- Lift burner using hoisting ring **19\*** (fig.9-10).
- Tighten the 4 fastening screws **S2** (fig.8) (check the tightening torques).

\* Alternatively a forklift truck may be used for fixing it if the burner is fixed to the transport pallet supplied with it. Provision must be made for adequate transportation safety. Suitable transportation materials must be used if necessary (lashing straps).

The leaktightness of the connection between the burner and the boiler must be tested during operation. It must be ensured that exhaust cannot escape in harmful quantities. Poorly sealed burner boiler connections may result in combustion problems.

If the weight and dimensions do not allow for manual lifting, ask another operator for help or use a forklift, harness the burner using belts if no eyebolts are available.

### Important

If the system is converted from natural gas type E to L or LL, the burner must be reset. It is necessary to modify the combustion components (kit available).

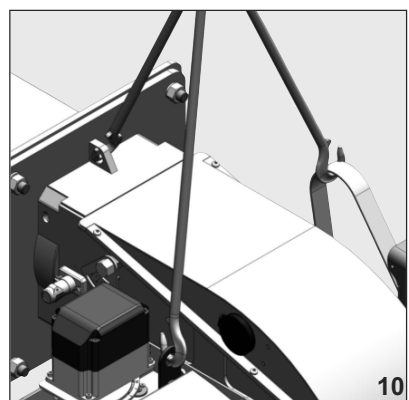
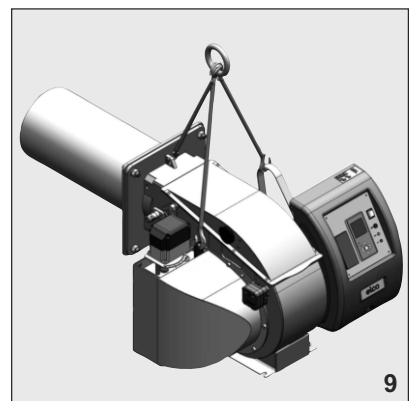
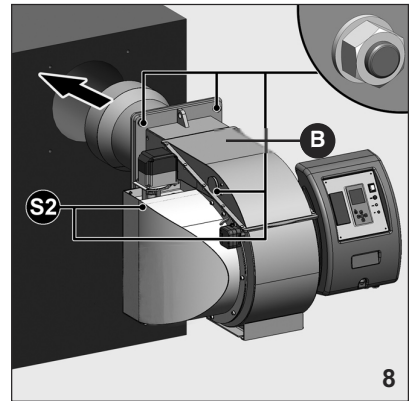

en

## Installation Combustion components

### Combustion components EK-TRON 5.300 - 6.400 G-R F3 adjustment data/check.

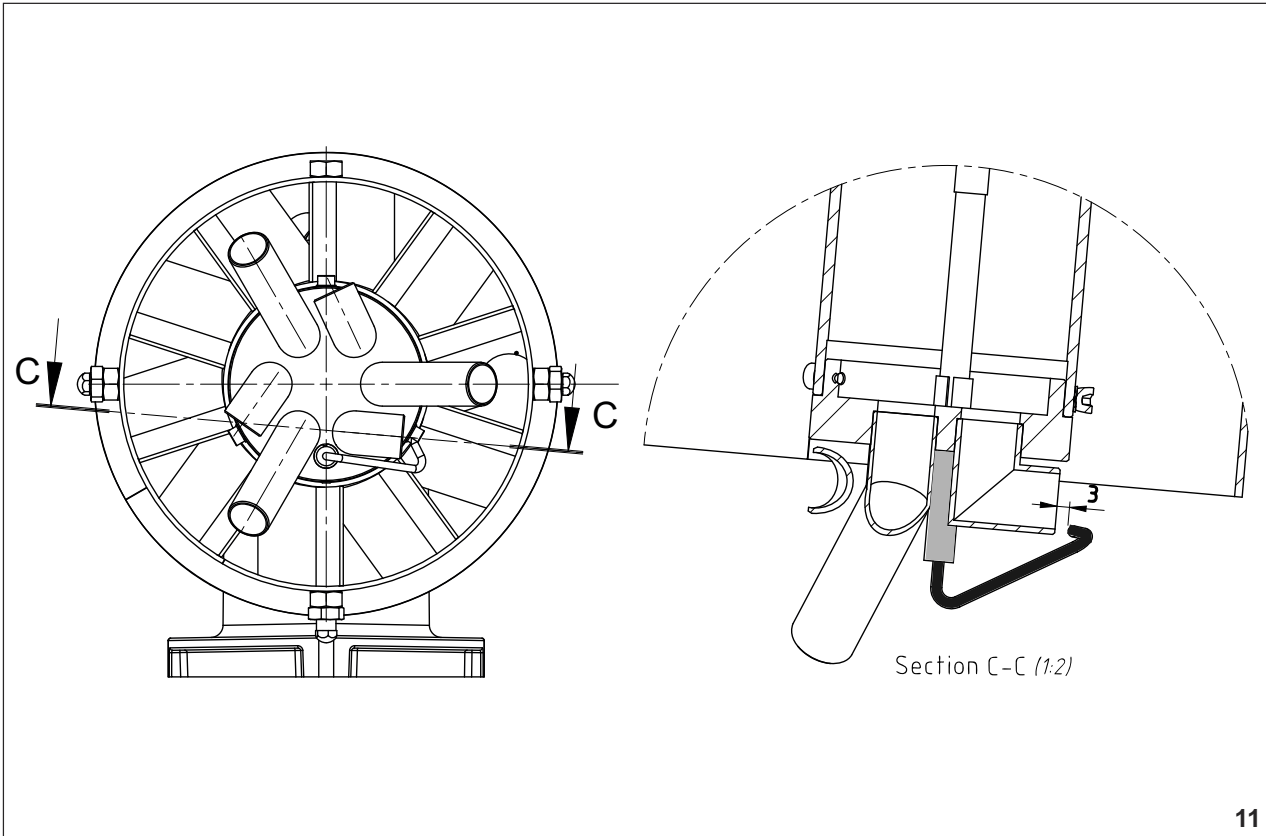

#### Firing head setting (C).

Execution :

- Loosen the locking screw of adjusting device V.
- Move the adjusting device until the desired position is reached.
- Tighten the locking screw with torque of 6-8 Nm.

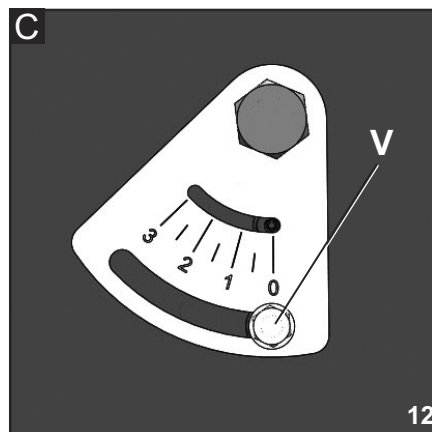

## Installation Combustion components

### Combustion components EK-TRON 7.5-600 G-R F3 adjustment data/check.

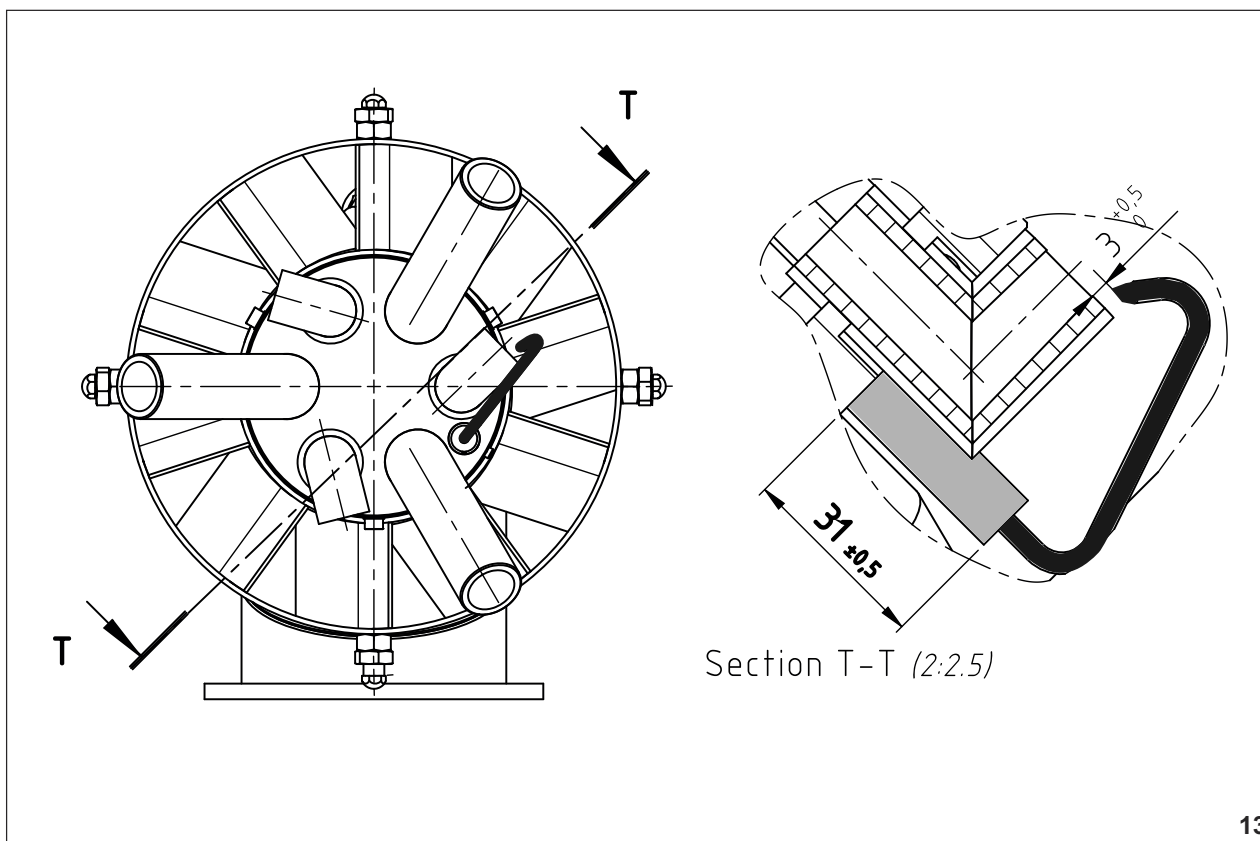

#### Firing head setting (C).

Execution :

- Loosen the locking screw of adjusting device V.
- Move the adjusting device until the desired position is reached.
- Tighten the locking screw with torque of 6÷8 Nm.

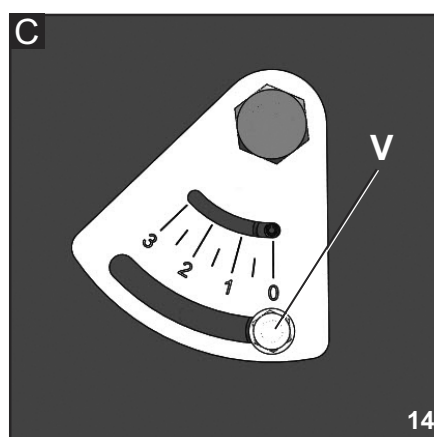

# Installation

## Combustion components

### Ignition electrodes adjustment data/check

---

**Note:**

If there are any ignition or flame detection problems, check the setting and dimensions of the electrodes. If the wear is too great, replace the electrodes.

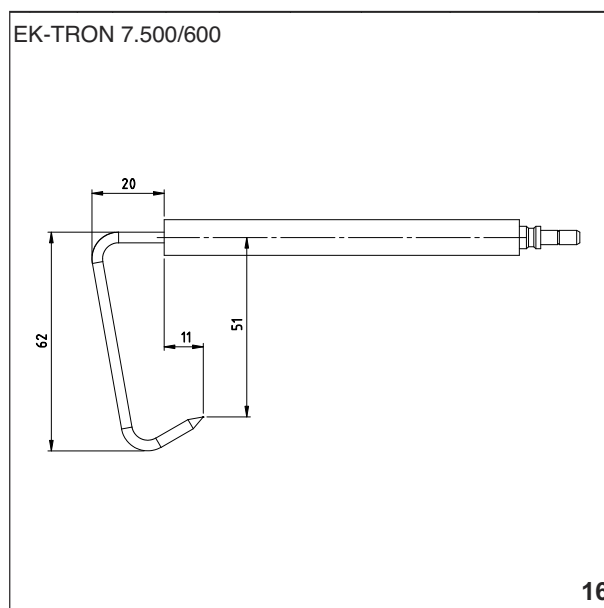
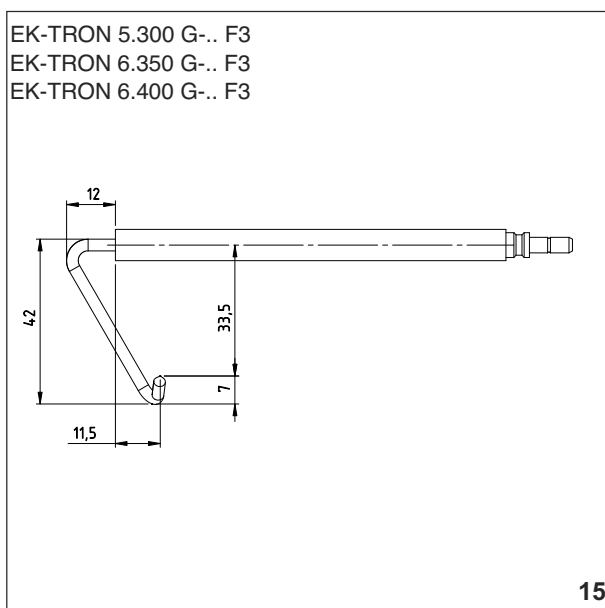

**Note:**

If there are any ignition or flame detection problems, check the setting and dimensions of the electrodes. If the wear is too great, replace the electrodes.

# Installation

## Gas train

### Description of gas train with VGD...

#### Description

Gas trains with a Siemens VGD double valve are intended for the supply, main shut-off, filtration, pressure regulation and monitoring of the gas supply. They can be used for all gases in the 1, 2, 3 gas families in accordance with DVGW worksheet G 260/1 and/or EN 437. The design complies with EN 676. All the functional components have been tested individually and awarded the CE mark and number of the Notified Body. The pre-mounted gas valve train is subjected to a leak test at the manufacturer's works. The rules of the DVGW, particularly the DVGW-TRGI and TRF, must be taken into consideration when the gas lines are being installed and commissioned. DIN 4756 and TRD 412 contain stipulations concerning the construction, design and technical safety principles of oil firing in heating systems. DVGW work sheets G 460 and G 461 apply to systems with high operating pressures. The gas lines must comply with the stipulations of DVGW-TRGI for systems with operating pressures of up to or greater than 100 mbar.

#### Minimum scope of delivery for gastrains in accordance with EN 676:

- 1 manual valve (optional)
- 1 Gas filter
- 1 Gas double valve
- 1 SKP15 actuator and 1 SKP25 or 1 SKP75 actuator
- 1 min. gas pressure switch
- 1 leakage monitoring unit or 1 gas pressure switch for valve leak test

#### Options:

- Manual valve
- Test burner with pushbutton valve
- Pressure gauge with pushbutton valve
- Compensator
- Max. gas pressure switch
- Gas meter
- Pipe parts and connection parts
- Ignition gas device
- Installation supports
- High-pressure regulator with safety shut-off valve (SSOV).
- Settling section with pulse lines for high-pressure regulator.
- Safety relief valve (SRV)
- Additional gas safety valve

#### Gas train with VGD

##### Technical data:

Types of gas:

Gas types of gas families 1, 2 and 3 according to DVGW Worksheet G 260/1

Max. inlet pressure: 500 mbar

Elect. connection: AC 220-240 V, 50 Hz

Protection level: IP 54

Ambient temperature:  
-10°C to +60°C

Media temperature:  
-15°C to +60°C  
(Liquid gas 0°C to +60°C).

#### Low- and high-pressure gas trains

If the outlet side of the regulator, or individual fittings and devices downstream of the gas pressure regulator, have not been designed for the maximum supply pressure that occurs in the event of a fault, the gas train must be equipped with a safety shut-off valve (SSOV) and a safety relief valve (SRV) in accordance with EN 676. This equipment is generally required for maximum supply pressures of >360 mbar and > 500 mbar respectively. These are known as high-pressure gas trains. If all gas train fittings and devices have been designed/approved for the maximum supply pressure that occurs in the event of a fault, the gas train is known as a low-pressure gas train. This is the case, depending on component selection, for maximum supply pressures of 360 and 500 mbar.

#### Gas train selection

The gas train is defined on a systemspecific basis.

The following must be taken into consideration:

- Burner output
  - Furnace counterpressure
  - Gas pressure loss in the burner head
  - Gas pressure losses in the gas valves
- The total drop in gas pressure must always be lower than the available gas flow pressure.

**Subject to change without notice due to ongoing technical developments.**

#### Gas train installation

To fit the gas train supplied to the burner, the screw connections and seals provided for this must be used (supplied with the product).

**Please note:** in order to prevent injury, heavy gas train components should only be fitted using suitable aids and lifting equipment (crane, cable slings, assembly supports). The max.

tightening torques must be observed (see chapter on Installation/tightening torques). The screw connections tightened crosswise and evenly. The screw connection must be checked to ensure that it is leaktight. For further information, please refer to the chapter on commissioning the gas connection.

#### Mechanical support

During and after installation of the gas train, mechanical support must be provided using at least one telescopic foot or a similar system (e.g. 1 on the filter and 1 on the valve).

# Installation

## Gas train

### Description of gas train with MBE...

---

#### Description

Gas trains with a Dungs MBE double valve are intended for the supply, main shut-off, filtration, pressure regulation and monitoring of the gas supply. They can be used for all gases in the 1, 2, 3 gas families in accordance with DVGW worksheet G 260/1 and/or EN 437. The design complies with EN 676. All the functional components have been tested individually and awarded the CE mark and number of the Notified Body. The premounted gas fitting train is subjected to a leak test at the manufacturer's works. The rules of the DVGW, particularly the DVGW-TRGI and TRF, must be taken into consideration when the gas lines are being installed and commissioned. DIN 4756 and TRD 412 contain stipulations concerning the construction, design and technical safety principles of gas firing in heating systems. DVGW work sheets G 460 and G 461 apply to systems with high operating pressures. The gas lines must comply with the stipulations of DVGW- TRGI in systems with operating pressures of up to or greater than 100 mbar.

#### Minimum scope of delivery for gastrains in accordance with EN 676:

- 1 manual valve (option)
- 1 Gas filter
- 1 double gas valve
- 1 actuator VD-V for safety shutoff valve operation
- 1 actuator VD-R for safety shutoff valve operation with integrated pressure regulation only in combination with pressure sensor
- 1 pressure sensor
- 1 min. gas pressure switch
- 1 max. gas pressure switch
- 1 leakage controller or 1 gas pressure switch for valve leak test.

#### Options:

- Manual valve
- Test burner with pushbutton valve
- Pressure gauge with pushbutton valve
- Compensator
- Gas meter
- Pipe parts and connection parts
- Ignition gas device
- Installation support
- High-pressure regulator with safety shut-off valve (SSOV)
- Settling section with pulse lines for high-pressure regulator
- Safety relief valve (SRV)
- Additional gas safety valve

#### Gas train with MBE

#### Technical data:

#### Types of gas:

Gas types of gas families 1, 2 and 3 according to DVGW Worksheet G 260/1

Max. inlet pressure: 500 mbar

Elect. connection: AC 100-240 V, 50-60Hz

Protection level: IP 54

Ambient and media temperature: -20°C to +60°C

#### Low- and high-pressure gas trains

If the outlet side of the regulator, or individual fittings and devices downstream of the gas pressure regulator, have not been designed for the maximum supply pressure that occurs in the event of a fault, the gas train must be equipped with a safety shut-off valve (SSOV) and a safety relief valve (SRV) in accordance with EN 676. This equipment is generally required for maximum supply pressures of >360 mbar and > 500 mbar respectively. These are known as high-pressure gas trains. If all gas train fittings and devices have been designed/approved for the maximum supply pressure that occurs in the event of a fault, the gas train is known as a low-pressure gas train. This is the case, depending on component selection, for maximum supply pressures of 360 and 500 mbar.

#### Gas train selection

The gas train is defined on a systemspecific basis. The following must be taken into consideration:

- Burner output
- Furnace counterpressure
- Gas pressure loss in the burner head
- Gas pressure losses in the gas valves

The total drop in gas pressure must always be lower than the available gas flow pressure.

#### Subject to change without notice due to ongoing technical developments.

#### Gas train installation

To fit the gas train supplied to the burner, the screw connections and seals provided for this must be used (supplied with the product).

**Please note:** in order to prevent injury, heavy gas train components should only be fitted using suitable aids and lifting equipment (crane, cable slings, assembly supports). The max.

tightening torques must be observed (see chapter on Installation/tightening torques). The screw connections tightened crosswise and evenly. The screw connection must be checked to ensure that it is leaktight. For further information, please refer to the chapter on commissioning the gas connection.

#### Mechanical support

During and after installation of the gas train, mechanical support must be provided using at least one telescopic foot or a similar system (e.g. 1 on the filter and 1 on the valve).

#### Max. Gas pressure switch

the DUNGS MBE gas valve must always be used in conjunction with a max. gas pressure switch. The max. gas pressure switch is supplied with every MBE gas train from Elco. Ensure during commissioning that the max. gas pressure switch is set correctly.

#### Pressure sensor

The MBE valve uses a fully electronic pressure sensor in combination with the VD-R actuator for pressure regulation. For the valve body DN50, the pressure sensor must be placed at a distance of 5x the diameter away from the valve body. For valve body DN65 - DN80 - DN100 the pressure sensor can be placed on the valve body flange. The pressure sensor comes in 2 variants:

PS-10/40 with operating range 4 to 100 mbar.

PS-50/200 with operating range 20 to 500 mbar.

Choosing the correct pressure sensor is therefore vital as it dictates the maximum pressure downstream the valve.

# Installation

## Gas train

### Basic design

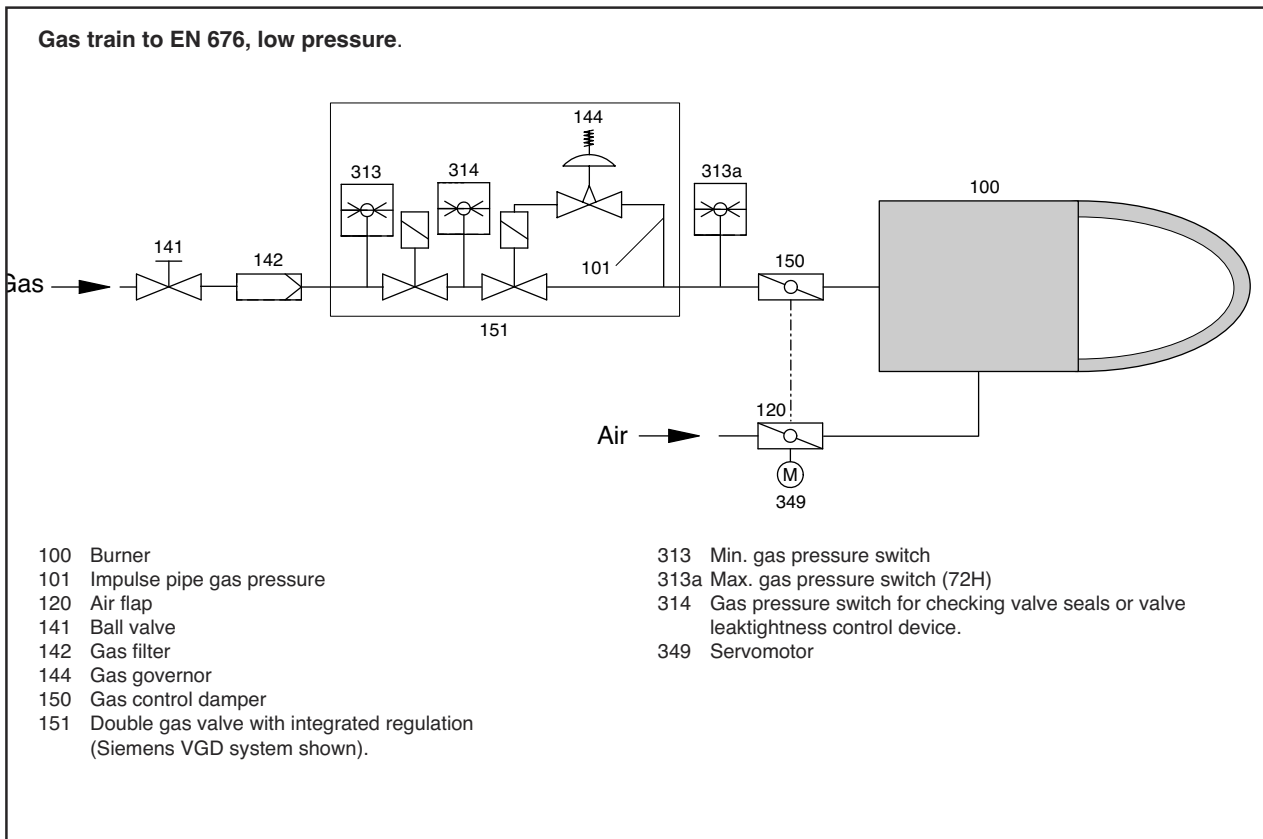

en

# Installation

## Gas train

### Description of double gas valve VGD with SKP servomotors



**Technical specifications**

**VGD double gas valves with SKP actuators:**

Type of gas:  
Gasses in accordance with DVGW worksheet G 260/1, gas families 1, 2, 3 and biogas (H2S content 0.1 vol.% max.), H2

Electrical data:  
220 V -15%...240 V +10%,  
100 V -15%...110 V +10%,  
50...60 Hz

Protection level: IP 54

Media temperature: -15°C to +60°C

Ambient temp.: -10°C to +60°C

Installation position:  
Magnet vertically upright or on its side, magnet horizontal.

Max. operating pressure:  
VGD20: 500 mbar  
VGD40: 700 mbar (DN 40 and DN 50 up to 1000 mbar).



#### Gas double valve VGD with actuators SKP

The combined servomotor and valve perform the following functions:

- safety shut-off valve Class A Group 2 in accordance with EN 161 with gas pressure regulator (SKP25..., SKP55..., SKP75...).

The electrohydraulically operated servomotors with valve are designed for gas types I to III and air, and are intended mainly for use in gas-fired furnaces. They are slow-opening and fast-closing. The actuator can be combined as desired with any of the valves and nominal widths specified above. The servomotor can be supplied with a limit switch (closed position signalling). Valve dimension information is provided on the "Throughput diagram" in the relevant valve datasheet.

The SKP25... operates as a constant pressure regulator with setpoint spring. It is mainly intended for use with forced draught burners.

- with mechanical compound;
- with electronic compound.

System accessories available for the double gas valve include the VPS 504 leak testing system and the GW...A5 pressure switch.

**WARNING** Install the burner on the boiler according to the installation position shown in (gas train). Installation 3 is forbidden for safety reason.

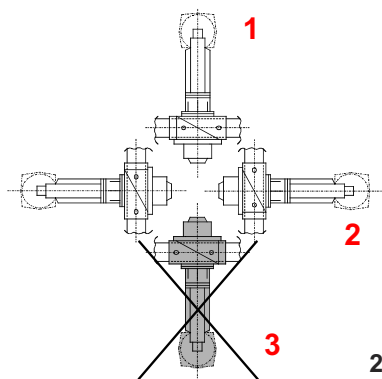

# Gas train components

## Gas filter

### Installation and mounting of the gas filter

The filter must be installed in a horizontal pipe. The vertical position of the cover makes cleaning easier. Be aware of the gas flow direction (see arrow on the filter housing). In addition, it is recommended that sufficient space is provided for dismantling without obstructing the cover and for replacing the filtering element.

### Filter replacement

The filter cartridge should be replaced by a new one as soon as a high pressure drop is noticed (pressure drop of more than 10mbar beyond the value observed with a new filtering element). If a new filter cartridge is not at hand it will be possible to wash the filter mat in 40°C water adding some light-duty detergent. Allow the mat to dry before reinstallation.

**Warning:** when installing the filter mat, ensure correct fixing or check the label.

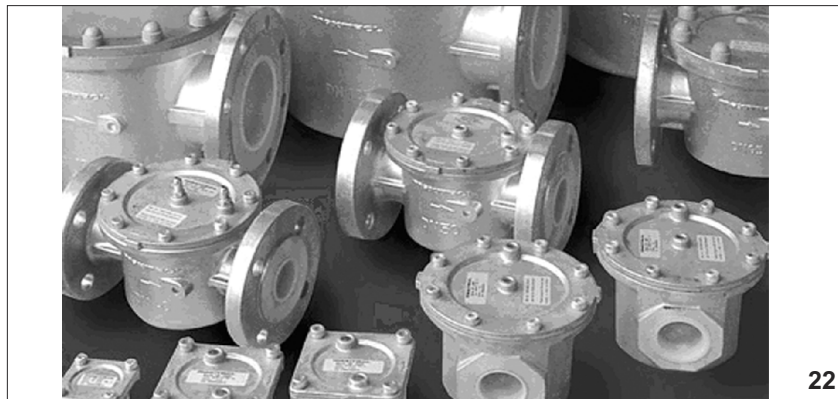

# Gas train components

## Gas pressure switch

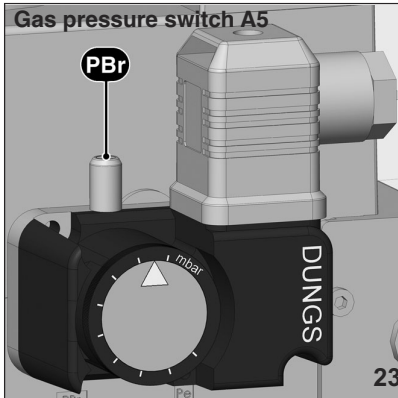

### Gas pressure switch GW...A5/A6

The gas pressure switch is designed to monitor the gas flow pressure. It can be used for monitoring either falling pressure (minimum) or rising pressure (maximum, specified for equipment according to TRD 604).

The types GW...A5/A6 may be used as pressure switches of a specific construction according to VdT V leaflet "Pressure 100/1" for application in furnaces complying with TRD 604. The setpoint (switching point) is adjusted using a setting wheel with scale.

#### Technical data:

Type of gas:  
Gases according to DVGW Worksheet G 260/1, gas families 1, 2, 3.

Protection level: IP 54

Ambient temp.: -15°C to +50°C

Installation position: any.

Operating pressure up to:  
GW 50/150 A5/A6 500 mbar  
GW 500/ A5/A6 600 mbar



### Setting the min. gas pressure switch

Remove the protective cover. At the rated output, measure the gas flow pressure and calculate the switch-off pressure by reducing by approximately 20%. Adjust the graduated disc to the desired switch-off pressure opposite the arrow (the graduations are approximate values). Operate the burner at minimum power. Close the gas cut-off valve slowly to obtain the desired switch-off pressure. Turn the graduated disc until the burner switches off. Refit and screw down the protective cover.

### Max. gas pressure switch

Remove the protective cover. At the rated output, measure the gas flow pressure and calculate the switch-off pressure by increasing by approximately 20% (no more than 30% under any circumstances). Adjust the graduated disc to the desired switch-off pressure opposite the arrow (the graduations are approximate values). Operate the burner at minimum power. If the max. gas pressure switch switches off the burner, increase the adjustment value but not to more than 130% of the flow pressure at the rated output.



### Certification

The pressure switch has been tested in accordance with EN1854 and is CE/ DIN-DVGW-registered. It has been registered in other important gas consumption countries.

### N.B. (Gas and air pressure switches)

**The pressure switches must be set in accordance with the specifications. Furthermore, each time they are set, a function test must be carried out. Non-compliance could result in personal injury or damage to property!**

**Once the pressure switches have been set, they must be protected to prevent settings from being altered. For example, this can be done by placing a spot of varnish on at least one of the screws on the equipment's protective cover.**

# Gas train components

## Air pressure switch



### Air pressure switch

The air pressure switch is provided for monitoring the pressure of the combustion air fan. Pressure switch LGW... is suitable for switching an electrical circuit or for switching it on or off if the actual pressure values are changing in relation to the setpoint. The pressure switch LGW... can be used as an overpressure, vacuum or differential pressure switch for air and nonaggressive gases but not for gases according to DVGW Worksheet G 260/l.

### Certification

The pressure switch has been tested in accordance with EN1854 and is CE/DINDVGW-registered. It has been registered in other important gas consumption countries.

### N.B. (Gas and air pressure switches)

**The pressure switches must be set in accordance with the specifications. Furthermore, each time they are set, a function test must be carried out.**

**Non-compliance could result in personal injury or damage to property!**

**Once the pressure switches have been set, they must be protected to prevent settings from being altered. For example, this can be done by placing a spot of varnish on at least one of the screws on the equipment's protective cover.**

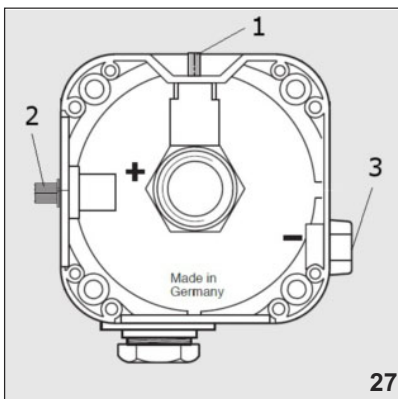

### Determining the differential pre-flushing pressure and adjusting the differential pressure switch.

#### Setting for operation without frequency converter

- Burner in the preventilation phase.
- Measure the pressure at the test connection (2).
- Measure the vacuum at the test connection (3) or directly at the air box (item 4).
- Add the measured pressures.
- Set the scale to 90% of the calculated value.

#### Alternative procedure:

- Pre-set pressure switch to maximum value (2.5 mbar).
- Burner at max. power.
- Slowly increase the differential pressure setting at the pressure switch until the burner shuts off.
- Set 90% of the measured shut-off pressure on the scale.

#### Setting for operation with frequency converter

- Burner with min. calorific power. \*
- Measure the pressure at the test connection (2).
- Measure the vacuum at the test connection (3) or directly at the air box (item 4).
- Add the measured pressures.
- Set the scale to 90% of the calculated value.

#### Alternative procedure:

- Pre-set pressure switch to maximum value (2.5 mbar).

- Burner with min. calorific power. \*
- Slowly increase the differential pressure setting at the pressure switch until the burner shuts off.
- Set 90% of the measured shut-off pressure on the scale.

\* The basic principle is that for a minimum load the motor frequency is set to the minimum and that the motor frequency setting increases with the increase in the load.

#### Important note:

After the adjustment procedure, it is necessary to check that the air pressure switch is operating correctly across the entire power range. It may then be necessary to modify the air pressure switch setting, even if the setting and operation are correct. In this case, the switching pressure can be reduced in stages (5% max.). At each stage, it must be ensured that the chosen setting is sufficient.

#### Switch function test

- The switch functions can be tested using the test button (with safety shutoff and locking). If the pressure switch functionality check is required with full load, press button (item 1). To test the burner in partial or full load, the vacuum line must be detached from the pressure switch measuring point (item 3 or 4). This removes the vacuum and the required differential pressure is not reached, and the burner goes into fault.

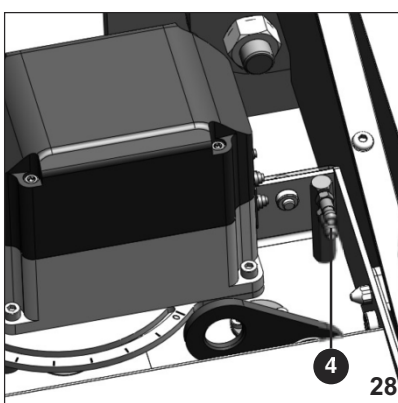

en

# Commissioning Electronic burner controller

## Description

### Description

The electronic burner controller is a programmable automatic firing device with an integrated electronic compound controller. There may be additional functions, depending on the equipment and model. The following burner-specific controllers are used.



<b>Burner controller</b>	<b>LME73.xxx / LME75.xxx (72H)</b>
<b>Manufacturer</b>	Siemens
<b>Technical data</b>	Operating voltage: 230 VAC Frequency: 50/60 Hz Power consumption: <10 W, typical Ambient temperature: during operation: -40°...+60°C Storage: -40° to +70°C 1 motorised actuator output (230VAC, 0,1A )(only LME71.../LME73...)
<b>Operating mode</b>	Intermittent operation / Continuous operation (72H)
<b>Components and integrated functions</b>	- Burner control. - BCI for connection a display or PC. - Lockout reset button (info button). - 3 multi color signal lamp LED for operations and fault notifications. - Interface for program module. - Optional: 3 x 7 segment display for fault and state information's and parameter display (only LME71.../LME73...). - Control for one actuator SQN3., SQN7., SQM40., SQM41..., SQM50... (only LME71.../LME73...). Customer interface integrated valve leak check
<b>Optional equipment</b>	- Service tools - AZL2..display, - Flame detectors, - Analog inputs for load controller DC 0...10 V, DC 0/4...20 mA, 0...135 Ω

Additionally, some burners are delivered without a controller and all components are connected to a terminal block. The burner controller in this case does not form part of the burner's scope of delivery.

Burners equipped with the LME73.xxx control unit are controlled and regulated using a manual terminal (display) or PC software. Save the data after starting the burner and after changing any data in the control unit (e.g. changed curves or parameters.). To this end backup all the data. The relevant procedure is described in the operating instructions. This will allow the burner to restart easily and quickly after replacing the control unit.

relevant electrical diagram for the burner and all local standards and legal regulations must be observed. The procedure described in the relevant operating instructions for the burner controller must be observed. The burner controller has a burner-specific factory setting. At the time of initial commissioning, it must be checked whether the parameters have been appropriately configured to meet the requirements of the system. The servomotors must similarly be checked for correct adjustment. During the I/O test, the manual gas shutoff valves must be kept closed at all times. It is not permitted to extend fixed safety times using external circuitry.

### Commissioning

Commissioning must be carried out by trained and expert personnel only. For the wiring of the system, the

# Commissioning Electronic burner controller

## Electronic burner controller (display)

### 5 List of phase display

Phase number of display 7-segment	LED	Function
LOC	OFF	Lockout phase
<b>Standby</b>		
OFF	OFF	Standby, waiting for heat request
P08	OFF	Power ON/test phase (e.g. detector test)
<b>Startup</b>		
P21	Yellow	Safety valve ON, air pressure switch in no-load position Test if POC closed (timeout/lockout after 5 seconds) Actuator travels in CLOSED position (timeout)
P22	Yellow	Part 1: Fan motor ON Part 2: Specified time air pressure switch Message (timeout), stabilization air pressure switch
P24	Yellow	Actuator travels in prepurge position (timeout)
P30	Yellow	Part 1: Prepurge time without extraneous light test *1 Part 2: Prepurging with extraneous light test (2.1 seconds)
P36	Yellow	Actuator travels in ignition load position (timeout)
P38	Yellow	Preignition time
P40	Yellow flashing	Postignition time
P42	Green	Flame detection
P44	Green	Interval: End of safety time and fuel valve 2 ON
P50	Green	Interval: Fuel valve 2 ON and pilot valve OFF
P54	Green	Parameter 259.01: Actuator opens to a position > low-fire Parameter 260: Actuator closes until low-fire position is reached
<b>Operation</b>		
xx	Green	Operation (modulation), display of the actual value in percent (%)
oP1	Green	Interval until load controller release
<b>Shutdown</b>		
P10	OFF	Home run
P72	Yellow	Actuator travels in postpurge position (timeout)
P74	Yellow	Postpurge time *2
<b>Valve proving</b>		
P80	Yellow	Test space is evacuated
P81	Yellow	Test atmospheric pressure
P82	Yellow	Test space is filled
P83	Yellow	Test gas pressure
<b>Safety shutdown phases</b>		
P01	Yellow / red	Under voltage / over voltage
P02	Yellow	Safety shutdown (e.g. open safety loop) → lockout
P04	Green / red	Extraneous light in standby
P90	Yellow	Gas pressure switch-min open → safety shutdown and start prevention

\*1 Valve proving during prepurging, if  
- parameter 241.00 = 1 and parameter 241.02 = 1 or  
- parameter 241.00 = 1 and parameter 241.01 = 0 or  
- parameter 234 (postpurge time) = 0 seconds

\*2 Valve proving during postpurging, if  
- parameter 241.00 = 1 and parameter 241.02 = 1 or  
- parameter 241.00 = 1 and parameter 241.01 = 1 and  
- parameter 234 (postpurge time) >0 seconds

# Commissioning Electronic burner controller

## Display

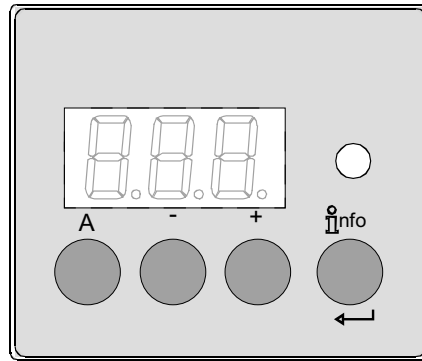

Button	Function
	<b>Button A</b> - Display preset output - In lockout position: Power value to the time of fault
	<b>Info and Enter button</b> - <b>Reset</b> in the event of fault, changeover visual diagnostic of the cause of fault (see chapter <i>Diagnostics of cause of fault</i> )
	<b>- button</b> - Display flame signal current 2 or phases display - In lockout position: MMI phase to the time of fault
	<b>+ button</b> - Display flame signal current 1 or phases display - In lockout position: MMI phase to the time of fault
	<b>3 multicolor signal lamp</b> - See chapter <i>Blink code table</i>
	<b>+ and - button: Escape function</b> (press  and  simultaneously) - No adoption of value - One menu level up - Keep depressed for >1 second for backup / restore function

# Commissioning Electronic burner controller

## Servomotor

Position indication SQM40...  
External angle scale  
Marking in slot shape

Position indication SQM41...  
Internal angle scale  
Arrow marking

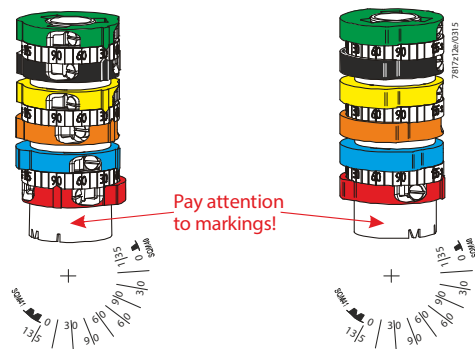

**Note!**

The setting of the switch positions must be checked before startup.

en

# Commissioning Electronic burner controller

## First startup with a new program module or in case of replacement of program module.

	LCD Bild 21/1108	  	Display shows alternately <b>rSt</b> and <b>PrC</b> .
Alternately			LCD Bild 22/1108

  >3 s			Press  for >3 seconds to start data download from the program module. Signal lamp blinks yellow. The process of 3 seconds is supported by a short flash of the yellow signal lamp.
	<b>Note:</b> If you press  for <3 seconds, data download does not start. To start the restore process again, the LME7 must be reset by switching mains ON/OFF.		

	LCD Bild 26/1108	Display shows <b>run</b> during download (restore process) of the program sequence.
--	------------------	---

	LCD Bild 23/1108		Display shows alternately <b>End</b> and <b>rSt</b> .
Alternately			LCD Bild 21/1108

After 2 minutes, the unit changes to **Loc 138**



		LCD Bild 06/0908		<b>After the restore process, the unit is automatically in the lockout position (LOC 138) and must be reset for operation!</b>
	Alternately			



  >1 s		LCD Bild 02/0908	Press  for >1 second to reset the unit.  Display: <b>OFF</b>
--------------	--	------------------	--







**Warning!**  
On first startup or after exchange of the program module, the sequence of functions and parameter settings must be checked upon completion of the restore process

# Commissioning Electronic burner controller



## Manual backup

 <p>LCD BId 22/1108</p>	<p>Press  and  simultaneously for &gt;1 second (Escape) to start a manual backup process. Parameter <b>PrC</b> appears.</p> <p>Display: <b>PrC</b></p>
--	--

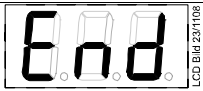

 <p>LCD BId 27/1108</p>	<p>Press  or  for parameter <b>bAC</b>.</p> <p>Display: <b>bAC</b></p>
--	--

 <p>← 1...3 s</p>	
--	--

 <p>LCD BId 28/1108</p>	<p><b>run</b> appears during download (backup process) of the program sequence.</p>
---	---

 <p>LCD BId 23/1108</p> <p>Alternately</p>  <p>LCD BId 27/1108</p>	<p>Display shows alternately <b>End</b> and <b>bAC</b>.</p> <p>Display shows the end of data exchange.</p>
--	--

<p>Display appears for 2 minutes or can be finished by pressing  .</p> <p style="text-align: center;">↓</p>	
--	--

 <p>← &gt;1 s</p>	 <p>LCD BId 02/9008</p> <p>When the backup process is completed, the display shows <b>OFF</b>.</p> <p>Press  for &gt;1 second to reset the unit.</p> <p>Display: <b>OFF</b></p>
--	---



**Warning!**  
If any parameters are changed, a backup must be made!  
If not observed, there is a risk of impairment of safety functions!

### Error during backup process

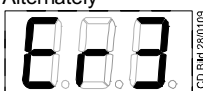
 <p>LCD BId 27/1108</p> <p>Alternately</p>  <p>LCD BId 28/1108</p>	<p>Display shows alternately <b>bAC</b> and <b>Er3</b>.</p> <p>For meaning of a possible cause, see chapter <i>Error code list with operation via internal LED</i>.</p>
--	---



**Note:**  
During backup, all settings and parameters are transferred from the basic unit's memory to the memory of the program module.

en

# Commissioning Electronic burner controller

## Manual restore

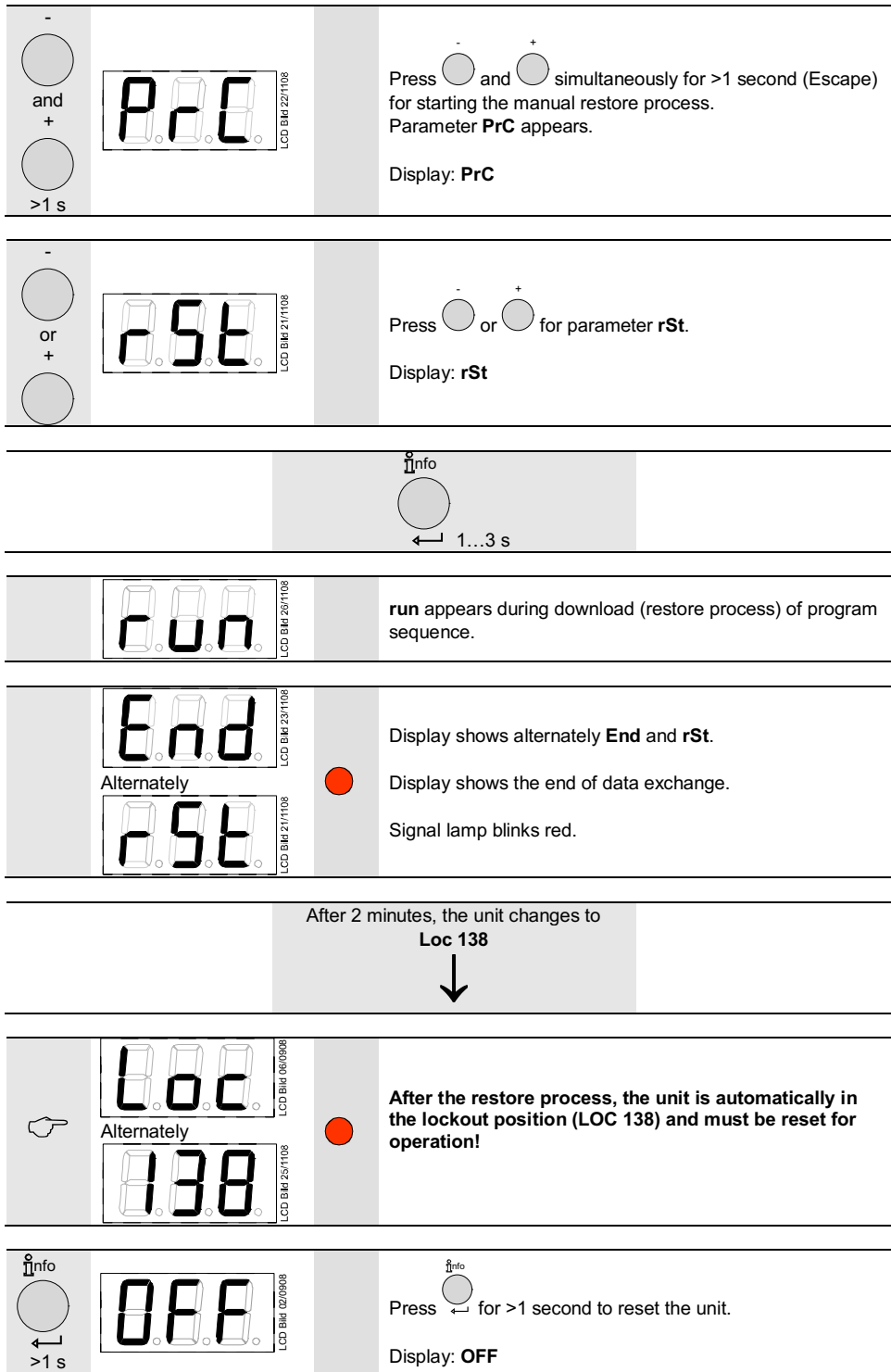

# Commissioning

## Switch cabinet door layout

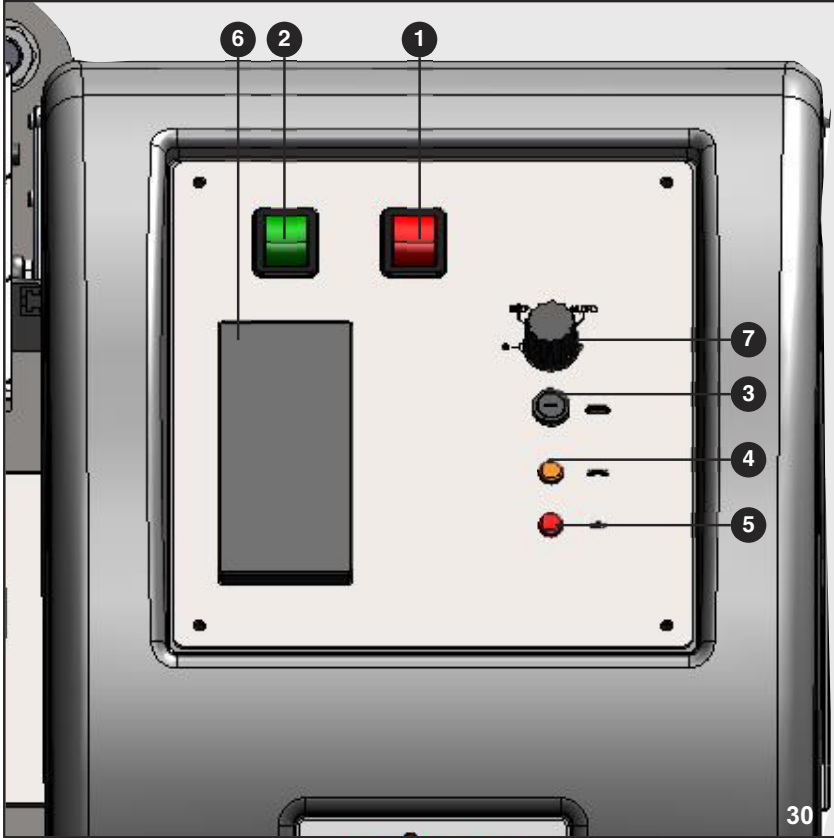

- 1 Reset button.
- 2 Power switch on / switch off with light indicator.
- 3 Auxiliary line fuse.
- 4 Thermal lock-out lamp.
- 5 Burner working lamp.
- 7 Selector.

**Note:** The above information is for standard equipment. Burners with a separate control system (Etamatic) and the "solid door" option do not have premounted frames in the control cabinet.

en

# Commissioning

## Servomotor SQM40.xxx

The LME73.xxx electronic control system works with the SQM40.xxx numerically controlled servomotor. For monitoring the function and direction of rotation, there is a driver with digital feedback via encoder disc. Observe the commissioning procedure. The connection is documented in the burner wiring diagram.

**Note:**

Before commissioning, the zero position of the servomotors **MUST** be checked. The servomotor is sealed. Opening the servomotor invalidates the warranty!



**Technical data:**  
**SIEMENS SQM40.281A20**

Voltage: 230 V AC  
Frequency: 50 Hz  
Angle of rotation:  
Direction of rotation: Counterclockwise  
Running time: 30 sec. for 90°  
Nominal torque: 10 Nm  
Static holding moment: 50%  
Dimensions (W x H x D):  
93 mm x 174 mm x 149 mm  
Potentiometer (on request):  
Double potentiometer 2\*1000 Ω, 90°.  
Double potentiometer 2\*1000 Ω, 135°.  
Ambient temperature:  
During operation: -20°...+60°C  
(-15°...+60°C for 18 Nm).  
Storage: -20° to +60°C.

Model	SQM4x.xxxA2...
Power supply:	AC 230 V -15%/+10%
Operating frequency	50...60 Hz ±6%
Power consumption:	10 VA
Angle of rotation:	90° or max 135° depending on the type.
Run time:	5 s, 15 s, 30 s and 65 s, depending on type.
Nominal torque:	2.5 Nm / 5 Nm / 10 Nm / 18 Nm, depending on type.
Holding torque:	50% (Of the torque for types with 5 Nm, 10 Nm, and 18 Nm torque). 36% (Of the torque for types with 2.5 Nm torque).
Dimensions (WxHxD):	93 x 174 x 149

The SQM4x.xxx servomotor is used in conjunction with various electronic compound control systems. With some types of burner, the motor is also used as a servomotor for other servo components independently of the compound control system (e.g. nozzle rod safety adjustment). Please refer to the appropriate section of the operating instructions.

The electrical diagram for the burner shows how to establish the servomotor's electrical connection.

Observe the documentation issued by the manufacturer.

# Commissioning

## Flame sensor

The flame sensor is a component of the flame monitoring system. In interaction with the automatic combustion control unit, it suppresses stray flame during burner start-up and monitors the presence of flame during burner operation.

Depending on the requirements of the burner and fuels, the flame sensor may be an optical sensor that monitors light radiation in the ultraviolet, infrared or visible spectrum emitted by the flame. In some gas burners, flame monitoring is achieved by means of ionisation.

In this case, no optical flame sensor is present. The flame sensors used are listed in the table below.

**Table: flame sensor**

Description	Spectral range	Area of use	Connection	Operating mode	Manufacturer	Comments
QRA 2	UV	Gas and dual fuel burners	LME73.xxx	intermittent	Siemens	
QRA 73	UV	Gas and dual fuel burners	LME75.xxx	permanent	Siemens	

The appropriate type of flame sensor is selected based on the spectral range of the flame radiation, the mode of operation required and the burner controller used.

For the electrical connection, please refer to the electrical diagram and the supplementary information for the individual flame sensors contained in the manufacturer's documentation.

**Note:**

The flame sensors must be regularly inspected for dirt and cleaned as necessary. The sensor windows of the optical flame sensors must be kept free of dust. The ionisation rods must be checked for burn-up and replaced if necessary.



**Using a UV probe for flame monitoring**

With this monitoring method, the UV radiation from hot flame gases is used to create the flame signal. A radiation detector is a UV-sensitive tube with two electrodes to which voltage is constantly applied. When illuminated with light from the 190...270 nm range of the spectrum, it fires and applies current to the flame signal amplifier. The UV tube does not react to the after-glow of fireclay in the furnace, sunlight, daylight or the lighting used to illuminate the boiler room.

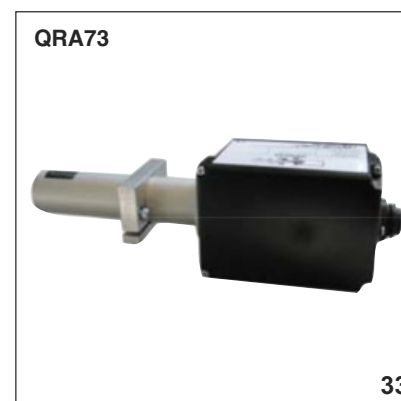

The tubes have a service life of approx. 10,000 hours at ambient temperatures of up to 50°C; higher ambient temperatures reduce the service life considerably.

**Cleaning the probe**

The UV sensor window must be checked at regular intervals for dirt, and then cleaned. The sensor window must be kept free of dust. If this measure proves unsuccessful, the tubes must be replaced.

en

# Commissioning

## Gas fitting connection Electrical connection Checks before commissioning

---

All electrical installation and connection work must only be carried out by a suitably qualified electrician.

 **N.B.:** The applicable guidelines and directives must be observed, as well as the electrical circuit diagram supplied with the burner. Before connecting the burner, it is essential to ensure that the entire burner has reached the ambient temperature. Otherwise, there is a risk that condensation will form on electronic components resulting in damage to property and personal injury!

### Gas fitting connection

The connectors on the burner must be used for connecting the gas valve. Cognisance must be taken of the equipment labelling and the electrical circuit diagram.

### Electrical connection

The electrical connections, i.e. the installation materials and all the connectors and earth/ground connections, must be installed in compliance with the specifications. The electrical installation of the burner must be carried out in accordance with the circuit diagram drawn up for the furnace. The electrical connection of the

burner may only be performed by authorised specialists.

 **The burner is not suitable for operation at 60 Hz or in any case at speeds above 2850 rpm. Elco declines all responsibility for damage due to operation of the burner at speeds above 2800 rpm!**

### WARNING

Electrical shock hazard! There is a risk of coming into contact with live parts! This could lead to fatal electrical shock! Before working on electrical components, switch off the electricity supply via an omnipolar cut-off switch. Check that the power supply is completely off and take all safety precautions to prevent involuntary reconnection.

### Please note:

When installing the connection cable, the cable loops selected must be large enough to allow the boiler door to swivel open. It is also essential to check the tightness of the electrical connections on the terminal blocks of all electrical motors. If necessary, tighten them within the maximum torque (see the chapter "General information regarding burner installation"). When electrical connection work is complete, the wiring

for the burner electrics must be checked. This includes checking the direction of rotation of the fan motor.

---

### Checks before commissioning

The following must be checked before initial commissioning:

- That the burner is assembled in accordance with the instructions given here.
- That the burner is pre-set in accordance with the values in the adjustment table.
- Setting the combustion components.
- The heat generator must be ready for operation, and the operating regulations for the heat generator must be observed.
- All electrical connections must be correct.
- The heat generator and heating system must be filled with water and

the circulating pumps must be in operation.

- The temperature regulator, pressure regulator, low water detectors and any other safety or limiting devices that might be fitted must be connected and operational.
- The exhaust gas duct must be unobstructed and the secondary air system, if available, must be operational.
- An adequate supply of fresh air must be guaranteed.
- A heat dissipation system must be available.
- Sufficient gas pressure must be available.
- The fuel supply lines must be

assembled correctly, checked for leaks and bled.

- A standard-compliant measuring point must be available for measuring the exhaust gas, the exhaust gas duct up to the measuring point must be free of leaks to prevent anomalies in the measurement results.

# Commissioning

## Gas connection

---

### Gas connection

The gas lines and trains should be installed and taken into operation in accordance with the applicable engineering standards and regulations.

The connection between the gas distribution network and the gas ramp must be performed by authorised persons.

All the gas train components must be fitted and installed without bending or distortion or any other form of mechanical stress.

The pipe diameters must be calculated so that the loss of load does not exceed 5% of the distribution pressure.

A quarter turn manual valve (not supplied) must be provided upstream of the gas ramp and the filter.

The max. operating pressure for the shut-off device must be 1.5 times the max. connection pressure. Ease of access must be guaranteed. Precautions must be taken to prevent unintentional actuation. The operating position of the gate valve must be quite obvious. The manually operated valve should have fixed stops in the "OPEN" and "SHUT" positions.

The filter must be installed on a horizontal nozzle with the cover in the vertical position to enable cleaning.

Depending on the current specification, a thermally triggered shut-off valve must be provided on site (not supplied).

All the gas ramp components must be protected against condensation and if necessary, a condensate trap (not supplied) must be provided on site.

The threaded unions used must be in conformity with present standards (tapered male thread, straight female thread with sealing provided in the thread).

Sufficient space must be provided for setting and maintaining the gas ramp components (gas pressure switch, valves, pressure regulator, gas filter, test burner etc.) (see technical data).

### Gas properties

Prior to any installation work make sure to obtain the following data from the gas supply company:

1. Type of gas
2. Calorific value  $H_{un} = \text{kWh/m}^3$  ( $\text{kJ/m}^3$ )
3. Max. CO<sub>2</sub> content of exhaust gas
4. Gas connection pressure and rest pressure.

### Type of gas test

Prior to mounting the burner to the gas feed line check the available type of gas and burner type against the data given on the burner nameplate (attached to burner). Be sure the description of the burner and the type of gas are the same as indicated on the nameplate.

### Gas connection pressure

A minimum connection pressure must be available upstream of the burner gas valve to ensure that the burner operates properly. Take care to observe the mounting instructions supplied by their manufacturers (these are packed with the valves). The gas line installed to the burner must be dimensioned in accordance with the throughput rate and the available pressure.

For selecting the nominal bore "DN" of the gas train care should be taken to observe the **flue resistance of the boiler and the gas pressure loss of the burner and gas train.**

### Please note:

The absence of impurities and foreign bodies must be checked before installation and commissioning of the gas ramp, the lever valves and unions.

### Gas train

The gas train can be connected directly to the gas feed line. **Take care to observe the correct order of installation and direction of flow (arrow on housing) of the valves.** Check the valves and connection pieces for absence of dirt particles and foreign matter before installation and initial operation. **To provide effective conditions for start-up make sure the distance between the burner and the gas stop valve is as short as possible.**

### Leak test

The fitted gas train must be leak tested

on the system in accordance with DVGW worksheets G600 and G490.

The gas line upstream of the burner gas train must be installed in accordance with the applicable regulations, leak tested, vented and certified accordingly by the gas installation company. The screw connections and flanged joints must be checked for proper leaktightness (by making a pressure test). The leak test must be made under pressure using approved foaming agents which do not cause corrosion. For steam boiler furnaces the result of the leak test must be duly certified.

### Venting

#### Please note:

Prior to putting the burner into operation or after any repair work make sure to vent the complete gas feed line and the gas valve group into the open atmosphere (e.g. by means of a hose) taking care to avoid any hazards.

**In no case should the gas line be vented into the heating or furnace chambers.**

Make use of a test burner to check the gas-carrying spaces are free from an inflammable gas mixture.

### Support

The train must be supported with a telescopic jacking member or similar during and after installation (e.g. on filter and valve).

### Joint

It is recommended to provide an easy-to-disconnect joint (with planar sealing faces) to facilitate repair work on the boiler (furnace) and allow the boiler door to be swivelled out if required.

# Commissioning

## Fuel-air compound control

### Fuel-air compound control

This finely tuned compound control system, which uniformly adjusts the fuel and air volume, makes it possible for the fuel-air ratio to be regulated to the optimum value across the entire control range. The infinitely variable control increases or decreases output to any point within the control range suitable for the current heat requirement.

### Electronic compound control

The air flap and the gas flap are each fitted with a servomotor that controls the position of these servo components. At the factory, the air curve of the compound controller is configured in such a way that the air flap is closed at the minimum setting and open at the maximum setting. As part of burner commissioning, the servo components for the fuel and air are assigned permanently defined positions in relation to burner output. During burner operation, the servo components move into these positions with great accuracy. This precision is a fundamental prerequisite for permanently ensuring low-emission combustion. The gas pressure should be corrected at the gas pressure regulator if necessary.

### Please note:

The gas outlet pressure (gas regulating pressure) must always be less than the gas inlet pressure but higher than the total pressure loss of the system.

**Proceed in accordance with the commissioning instructions for the electronic compound control system when making gradual adjustments to the load points (fuel flow rate, air flow rate).**

Where possible, a combustion measurement should be carried out at each point.

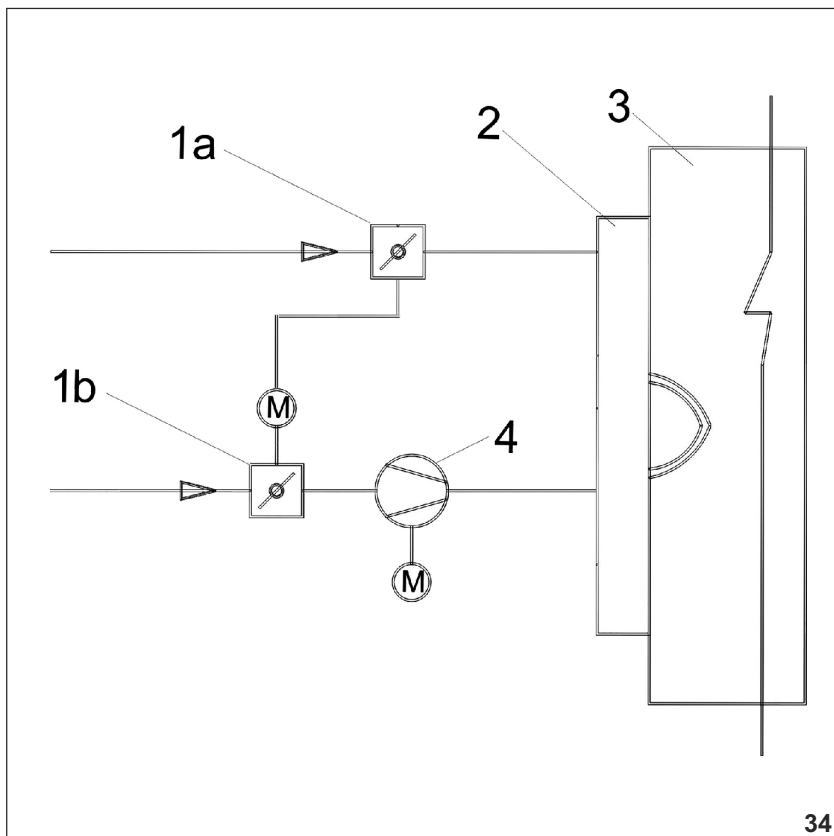

- 1a Gas damper
- 1b Air damper
- 2 Burner
- 3 Boiler
- 4 Combustion air fan

# Commissioning

## Burner power adjusting sequence

The burner is operated and adjusted using the display or a PC (serial interface).

### Before starting up the burner:

- set the control unit.
- pre-set the safety pressure switches (see each section: air, gas pressure switches).

### Follow the instructions in the "Checks" section!

### Adjusting sequence (Short description)

- Switch on burner (switch on control voltage and control chain).
- The burner program starts.
- Adjust prevention position of air flap (and also frequency converter if necessary) in accordance with required ventilation for boiler system (see chapter entitled Prevention).
- Set starting heat output of burner to max. 33% of nominal load (adjust primary gas pressure at regulator if necessary, see section entitled Gas pressure regulation).
- Burner adjustment over the entire load

range (the primary gas pressure must be adjusted at the regulator if necessary, see section entitled Gas pressure regulation).

- Check power setting and control behaviour in the event of a load change.
- Adjust safety pressure monitor (see respective chapter Gas, air pressure monitor).
- Check effectiveness of safety equipment (flame sensor, air, gas pressure monitor, leaktightness checking).
- Save burner control parameters on external data medium (recommendation).

### Please note:

If changes are made to the primary gas pressure, test all burner power settings. (O<sub>2</sub>, power, control range, burning behaviour, etc.).

### Note:

A gas pressure setting must be selected that keeps the gas flap as wide open as possible at maximum burner power. This provides good fuel control

behaviour over the entire load range (see also chapter entitled Gas pressure control).

en

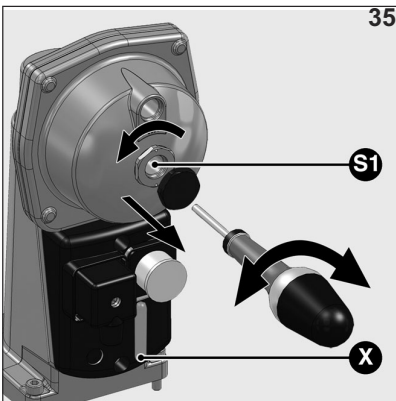

### Gas pressure setting VGD gas valve

- Remove protection cap on SKP25.
- Adjust gas pressure **pBr** (immediately downstream of double solenoid valve) using screw S1 (beneath lid) and a flat screwdriver.
- The stroke setting can be read off the scale X.
- After adjusting, the gas pressure setting must be secured to prevent it from being altered. This can be done by securing the lid (cover of S1) using sealing lacquer.

Other variants of the VDG can be found in the chapter entitled Double gas valve VGD.

### MBE gas valve

- Adjust the pressure downstream of the valve by using an allen key on the yellow adjusting screw.
- Please note the adjusting scale and equivalent downstream gas pressure is not linear.
- Consult the dedicated gas train kit manual for further details.

Other variants of the MBE can be found in the chapter entitled *Double gas valve Dungs MBE*.

A gas pressure setting must be selected that keeps the gas flap as wide open as

possible at maximum burner power. This provides the best possible fuel control behaviour over the entire load range.

### Please note:

Gas output pressure (regulator output pressure) must be adjusted lower than the input pressure, **but higher than the total gas pressure loss of the heating plant.**

**Once the burner has been commissioned, all of the safety devices must be checked to ensure correction settings and operation (in particular, see the Gas/air pressure switch section).**



# Commissioning

## Inspection

---

### **Before commissioning the system for the first time, the following inspections must be carried out:**

- Observe the operating instructions of the boiler manufacturer. The boiler must be fitted and ready to operate
- The heating system must be filled with sufficient water
- The entire system must be checked to ensure that the electrical wiring of all the system components is correct
- Check the direction of rotation of the burner motor
- Ensure that the temperature or pressure regulator, the limiter, the safety switches and electrical limit switches are set correctly.
- Check the gas connection pressure
- Check for leaks in the gas supply elements
- Are exhaust gas ducts open and is there an adequate supply of fresh air?
- Is the burner in the start position: air flap in the "CLOSED" position?
- The automatic firing device for the electronic compound is unlocked and in the starting position.

### **Warning:**

No object which is capable of being sucked up (for example, cloths, instructions) must be left within 0.5m of the burner air extraction intake. If these objects are sucked into the burner, it may lead to malfunctions and dangerous operating states. This may result in a switch to malfunction mode or damage to the environment and to the installation, and may even cause injury (risks of serious or fatal injury).

### **Gas commissioning**

- Connect the test devices for the gas head pressure on the test connection after the gas control damper and the air pressure on the test connection for the burner.
- Open the gas shut-off valve before the gas valves and check the gas pressure from the pressure gauge.

### **Before the first fuel release, a function test must be carried out on the burner program sequence.**

- Open the gas shut-off valve on the valve group briefly until there is pressure, then shut it again
- Start the burner and monitor the program sequence to ensure that the correct start-up sequence is followed:
  1. Valve leaktightness check
  2. Fan
  3. Pre-ventilation of air flaps
  4. Air pressure regulation
  5. Part load of air flap
  6. Ignition
  7. Open the valves
  8. Lockout after safety time expires (see automatic firing device) or system shuts down for a lack of gas.
- Unlock the automatic firing device for the electronic compound.

# Commissioning

## Preventilation

### Preventilation:

Care must be taken to ensure that the boiler system is adequately preventilated. The system-specific instructions must be observed. The burner is designed so that it is preventilated when the full load setting is selected. The preventilation times depend on the automatic firing devices and can be referred to in the relevant chapter.

Assuming the conditions in the area or the boiler unit are the same for preventilation and standard burner operation (loss of boiler pressure, temperatures), the air rate delivered by the burner for preventilation may be calculated as follows:

### Please note:

in the case of electronic compound controls (BT300/ Etamatic), the nominal load and nominal preventilation position may be different, depending on the setting. If this is the case, the heat output that is reached in the preventilation position during actual burner operation must be applied for the calculation.

$$V_{\text{air}} = \frac{Q_N \times V_{L\text{min}} \times \lambda}{H_i} \times \frac{(t_{\text{air}} + 273) \times 1013 \text{ mbar}}{273 \times p_{\text{amb}}}$$

$$V_{\text{air}} = \frac{3000 \text{ kW} \times 9,56 \text{ Nm}^3 / \text{Nm}^3 \times 1,17}{10,35 \text{ kWh} / \text{Nm}^3} \times \frac{(20^\circ\text{C} + 273 \text{ K}) \times 1013 \text{ mbar}}{273 \text{ K} \times 980 \text{ mbar}} = 3597 \text{ Bm}^3 / \text{h}$$

Example			
Nominal heat output setting	QN	3000	kW
Combustion air requirement	VL min	9,56	Nm <sup>3</sup> Nm <sup>3</sup> ; Nm <sup>3</sup> /kg
Calorific fuel value	Hi	10,35	kWh/Nm <sup>3</sup> ; Nm <sup>3</sup> /kg
Intake air temperature	tLuft	20	°C
Barometer level	pamb	980	mbar
Excess air	?	1,17	
Preventilation rate	VLuft	?	Bm <sup>3</sup> /h

en

Guide values		
	Calorific value Hi	Combustion air requirement VLmin
Natural gas E	10.35 kWh/Nm <sup>3</sup>	9.56 Nm <sup>3</sup> /Nm <sup>3</sup>
Natural gas L	8.83 kWh/Nm <sup>3</sup>	8.45 Nm <sup>3</sup> /Nm <sup>3</sup>

# Commissioning

## Gas start-up mode Gas operating mode

### Gas start-up mode

As soon as the furnace is required to supply heat, the burner control circuit will close and the program flow will start. When the program sequence ends, the burner starts up.

**An automatic test is made for the leaktightness of the gas valves prior to each burner start.**

**The air flap is in its closed position when the burner is out of operation.**

The electric servomotor will open the closed air flap to its full-load position so that the burner will ventilate the furnace and the exhaust hoods with the specified air rate. Shortly after the prevention process has been started, the lack-of-air cut-out must change over to the operating position within a certain time, i.e. the minimum air pressure setting must be reached and maintained until the burner is turned off. Once the prescribed prevention time has elapsed, the air flap and the gas control flap are moved to the partial load position. The ignition transformer is activated.

After the pre-ignition time, the main gas valves are open and the gas comes out from injectors where it is mixed in the combustion head with air coming from the fan. The ignition of the gas air mixture is done directly by a high voltage spark on a gas injector. During the safety time, a stable flame is formed and is monitored by a UV photocell.

The ignition is stopped before the end of the safety time and the burner operates at its minimum power. The start-up programme is completed.

### Gas operating mode

After flame formation, the burner will shortly remain in the separately set ignition load and is then run at minimum output. Output regulation will then be enabled. This brings the burner to its operating position. The controller will now automatically control the burner between its partial-load and full-load positions.

Depending on the heat demand, the output controller will actuate the electronic compound controller which in turn will control the actuators of the gas control damper and air control dampers and increase or decrease the flow rates according to a specific program.

The stepless control makes it possible to operate the burner at any desired stage between its partial-load and full-load positions. Burner shutdown occurs regardless of burner load state. It is advisable to program the load controller to have the shutdown occur at low load. The air flap will be closed when the burner is in its off position so as to prevent cold air from flowing through the furnace chamber, heat exchanger and chimney. The interior cooling losses will be greatly minimised.

**Warning:** If gate valves have been installed in the exhaust gas tract, they must be fully opened during the start-up phase, otherwise there is a risk of a lowspeed detonation or an explosion! The open-position of the flue damper can be assured by the integration of the opening contact of the shut-off damper in the safety chain of the heat generator.

### Important:

No object which is capable of being sucked up (for example, cloths, instructions) must be left within 0.5m of the burner air extraction intake. If these objects are sucked into the burner, it may lead to malfunctions and dangerous operating states. This may result in a switch to malfunction mode or damage to the environment and to the installation, and may even cause injury.

### Program sequence with gas leakage control

Program sequence with gas valve proving Gas valve proving during startup is performed only after a reset from the lockout position, after power ON, and when parameter 234 = 0 seconds.

In that case, gas valve proving takes place at the same time as prepurging. This means that the prepurge time corresponds to at least the sum of all 4 gas valve proving parameters (242, 243, 244, and 245).

Gas valve proving during shutdown is performed only if the postpurge time >0 (parameter 234 >0). If no postpurge time is parameterized, gas valve proving takes place during startup when prepurging.

During shutdown (heat request OFF), it is checked if parameter 241 = 1 (gas

valve proving ON) and parameter 234 ≠ 0 seconds before the valves close.

This means that, first, fuel valve 1 is closed. Fuel valve 2 remains open, so that the remaining gas in the test space can be burned. The postpurge time runs at the same time as gas valve proving. This means that the postpurge time corresponds to at least the sum of all 4 gas valve proving parameters (242, 243, 244, and 245).

During postpurging and valve proving, the actuator remains in the last running position.



### Warning!

The OEM must set the evacuation, filling and test times for atmospheric or mains pressure on every plant in compliance with the requirements of EN 1643. If not observed, there is a risk of impairment of safety functions.

It must be ensured that the 2 test times are correctly set. It is to be checked whether the gas required for the test may be fed into the combustion chamber (on the relevant application). The test times are safety-related. After a reset and in the case of aborted or prevented valve proving, the unit will perform valve proving the next time it is started up (only when valve proving is activated). In the case of valve proving, prepurging is active during the startup phase, even if it has been deactivated.

No.	Parameter
241.00	Valve proving 0 = OFF 1 = ON <sup>1)</sup>
242	Valve proving test space evacuating
243	Valve proving time test atmospheric pressure
244	Valve proving test space filling
245	Valve proving time test gas pressure

<sup>1)</sup> Valve proving during postpurging, if parameter 234 >0 (postpurge time) and parameter 241.01 = 1



**Note!** If terminal X2-02 pin 3 and terminal X2-02 pin 4 are bridged, the valve proving is deactivated.

# Commissioning

## Gas start-up mode Setting

Select the gas operation in order to proceed with start up on the gas side. On the selector put the operation on minimum capacity.

MAIN SWITCH

0 - OFF

1 - ON



**KMV contactor:** check the air fan motor rotation. If not correct invert the two phases on the power supply.

KMV

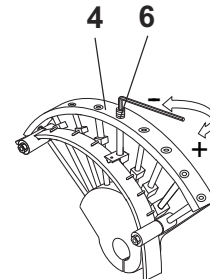
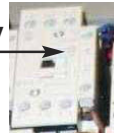

37

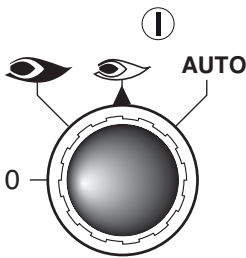

0 : operating elements locked in an intermediate position.

: operation on maximum capacity

: operation on minimum capacity

AUTO : automatic operation

**NB: burner regulation must always be carried out using the combustion analysis tool.**

### "R" VERSION GAS BURNERS GAS TRAIN INSTALLATION AND SETTING INSTRUCTIONS

Fix the gas train to burner body by means of the 4 screws of the flange, pay attention to set correctly the gasket ( O-ring ).

Connect electrically the gas train. Switch on the burner (it has already been tested in the factory, so it is pre set on average values) and verify the tightness of gas train connections made during installation. Act as follows to adapt the burner output to the boiler.

#### HIGH FLAME

1. Bring the burner in high flame , air inlet must be set at 90°.

To adjust air capacity operate on the combustion head position.

2. Regulate gas capacity in high flame through the gas governor, or operate on the adjustable gas valve.

#### LOW FLAME

The power for the low flame mode must be chosen within the working range.

Put the switch to the low flame position.

The servomotor will simultaneously close the air shutter and the throttle valve up to 15°(factory regulated). To regulate the gas flow, proceed as follows:

1. Measure the gas flow at the gas meter.

- If the gas flow needs to be reduced, reduce the angle of the cam III (SQM4...) of the servomotor with minor adjustments, gradually bringing the throttle valve to 13°/10°.....

- If the gas flow needs to be increased, move the switch to high flame mode

then increase the angle of the cam III (SQM4...) of the servomotor with minor adjustments, gradually bringing the throttle valve to 16°/18°. Put the switch back to low flame mode and measure the gas flow.

**N.B.:** the servomotor performs the regulation effectively only when the angle of the cam III (SQM4...) is reduced. If, on the other hand, it must be increased, it is necessary to move to the high flame mode and increase the angle of the cam, before returning to the low flame mode to verify the outcome.

#### MEDIUM POWER

1. Gas regulation.

- No regulation is required.

2. Air regulation.

- Put the selector to High Flame until the servomotor turns by roughly 15° then release it (position 0).

Adjust the screws of sector (4) until obtaining the desired combustion level. Repeat the operation, increase the rotation and adjust the other screws while trying to keep the blade moving progressively.

- Switch the burner off and release the servomotor (lever 5), thus detaching the latter's sector. Repeatedly turn sector (4) to the right and left while verifying that it moves smoothly without jamming. If necessary, adjust the relevant screws without altering those located at the ends and previously adjusted for low and high flame.

- Change progressively the final slope of the sector (4) by turning the screws :  
- for increase the air flow, turn screw (6) to the right,  
- for decrease the air flow, turn screw (6) to the left.

### Servomotor SQM40 - Air damper motor pre-setting

The cams of the servomotor are set from the factory in order to start the burner and reach the maximum output. The following setting are the standard one:

I. High flame position 90°.

II. Air flap position in standby 0°.

III. Low flame position gas 15° (can be modified depending on the minimum output of the boiler).

IV. Ignition position gas 10°.

V. To VI not used.

**(5): MANUAL RELEASE SWITCH**



38

### FIRING HEAD SETTING

Refer to setting pages 8 to 9.

en

# Commissioning

## General safety functions

---

### General safety functions

In case a flame does not develop when starting the burner (fuel release), the burner controller will shut off at the end of the safety period (lockout).. A lockout will also occur in the case of flame failure during operation, air flow failure during the pre-ventilation phase and pressure failure during the whole period of burner operation. Any failure of the flame signal at the end of the safety period and a flame signal during the pre-ventilation phase (external light control) will result in a lockout with the automatic firing device being locked. The fault is indicated by the fault signal lamp lighting up. The automatic firing device can be unlocked immediately after a lockout by pressing the unlocking key. The automatic firing device will return to its starting position and proceed with the restart of the burner. A voltage failure will result in a regular shut-off of the burner. After voltage recovery, the burner can be automatically restarted unless another interlock is active, e.g. one caused by the safety circuit. In any case, the fuel-oil supply will be immediately stopped upon occurrence of a fault.

When using the burner control system (electronic compound control) all operational and fault messages may be indicated in plain text on an optionally available operating and display module.

# Servicing

## Maintenance

**Burner and boiler servicing must only be carried out by a professionally qualified heating engineer. The system operator is advised to take out a service contract to guarantee regular servicing. Depending on the type of installation, shorter maintenance intervals may be necessary.**

**Please note:**

If maintenance is not carried out properly in accordance with these instructions, system malfunctions and dangerous operating conditions could ensue. This may result in a breakdown, damage to property and the environment and personal injury. A log must be kept of all maintenance and servicing work. All wear parts must be replaced in accordance with the specified cycle times (see table below).

 **For maintenance work, the floor of the work area must be free of dirt and slip-resistant. Provision must be made for adequate lighting. When maintaining heavy components (e.g. the fan motor), suitable lifting equipment must be used.**

Before carrying out any maintenance or cleaning work on the burner, the following steps must be followed.

1. Turn off the power supply and protect the system from accidental start-up.
2. Interrupt the supply of fuel.
3. Check the system for residual power and ensure that steps 1 and 2 have been effective.
4. Before opening the burner casing, ensure that the fan motor has stopped completely.

If the cooling fins of the ventilation motor are motionless, the turbine has stopped.

**Failure to observe these instructions may result in severe or fatal injuries and/or damage to property.**

• Use original spare parts.

If original spare parts are not used, the system may no longer be CE-compliant.

**Warning:**

Each time maintenance work is carried out, it is essential to ensure that no tools, cleaning cloths or other items are left in the burner housing. Any items left behind could affect the functionality of the burner and could result in damage to property or personal injury (risks of serious or fatal injury).

**Work recommended as part of annual burner maintenance:**

- Burner test run, input measurement in the boiler room.
- Clean the combustion components and replace defective parts if necessary.
- Clean the fan wheel and the fan
- Clean the gas filter; replace it if necessary.
- Check the setting of the combustion components and check the seal between the gas head and burner tube for leaks.
- Clean the FGR valve, flap and shaft from any corrosion or debris.
- Check operation of FGR valve.
- Check the ignition electrodes and ignition sparking. Clean and readjust if necessary.
- Clean the flame sensor.
- Clean the air flap and check that it moves easily.
- Check whether the fan wheel is deformed or cracked.
- Visual inspection of the burner's electrical components; eliminate malfunctions if necessary.
- Check burner start-up (combustion performance, emissions, burner output).
- Leakage test.
- Function tests on the burner's safety equipment, the safety chain for the boiler system (air pressure, gas pressure switches, the flame monitor, the leak detection device, the safety valves, the safety chain components). The maintenance and safety specifications for the boiler system must be complied with.
- Visually check the tightness of all fittings, especially the connections of all control mechanisms (gas valve, air vent) and the ventilation turbine, and tighten them if necessary.
- Check/clean the pressure pipe of the air pressure switch, in particular inside the air box hood (opening in the acoustic insulation.).
- Flame monitor and automatic firing device function check.
- Checking the gas circulation pressure upstream and downstream of the gas control system and checking the static gas pressure.
- Check the gas flow.
- Check the gas train for leaks.
- Check the gas valves for leaks and cleanliness.
- Clean the burner inside and out.
- Correct the adjustment values if

necessary.

- Draw up a measurement report\*.

\* The following values must be recorded at a minimum:

- Type of fuel, type of gas.
- Wobbe index (heat value); calorific value.
- Volumetric gas flow.
- Lowest and highest useful combustion efficiency; also 1 to 2 intermediate values.
- Gas and air pressures (gas connection, gas regulator, burner head, setting pressure, fan pressure, furnace pressure).
- Exhaust gas emissions (NO<sub>x</sub>, O<sub>2</sub>, CO, CO<sub>2</sub>, soot) as a percentage/ ppm.
- Temperature and humidity of the combustion air.
- Flue gases temperature.
- Atmospheric air pressure.

General checks

- Emergency stop button function check.
- Visual inspection of gas lines in the boiler room.

**Cleaning and lubricating instructions**

- Depending on the cleanliness status of the combustion air, the fan impeller, ignition electrodes, flame sensors and air flaps must be cleaned as required.
- For burner with mechanical compound controller:
  - lubricate ball heads on the adjusting screws for the compound controller.
  - The bearing points of the burner moving parts require no maintenance.
  - Damage to ball bearings should be detected and eliminated at an early stage to avoid greater consequential damage. Listen to the motor bearing noise to identify possible irregularities.

**Warning!**

Before restarting the burner following maintenance work, make sure that any unions unscrewed during maintenance work are tight and firmly in place. Check the connections of the components located in the burner (e.g. the parts of the combustion head) before closing the cover. Check the cover too. Incorrectly connected or defective components may cause malfunctioning and hazardous operation. This may result in a switch to malfunction mode or damage to the environment and to the installation, and may even cause injury (risks of serious or fatal injury).

# Servicing

## Maintenance

### Warning!

Replace any damaged or defective components! Replace safety components before their end of life! Never operate the burner with damaged

or defective parts. Using defective or damaged components may cause malfunctioning and hazardous operation. This may result in a switch to malfunction mode or damage to the

environment and to the installation, and may even cause injury (risks of serious or fatal injury).

Safety-related components	Recom. useful service life	Min. operating cycles
Gas and air pressure switches	10 years	-
Automatic firing device with flame monitor for the burner	10 years	250 000
Flame monitor (UV cells)	10,000 hours of operation	
Gas pressure regulator	15 years	-
Gas valve with valve testing system	after a fault is detected	
Gas valve without valve testing system	10 years	250 000
Fuel-air ratio control	10 years	-
Servomotor SQM 4... (Siemens)	Depends on usage	250 000
<b>Useful service life of wear parts *</b>		
Auxiliary relay	Depends on usage	50 000
Motor	40,000 hours of operation	

The list contains the minimum number of switching cycles and the shortest possible service life for wear parts\* and safety-related components. The actual service life could be much higher and this depends on the operating conditions. For reasons of operational and functional safety, the recommended periods of use should not be exceeded.

\* Wear parts in the case of 25 years of machine usage.

# Servicing

## Maintenance

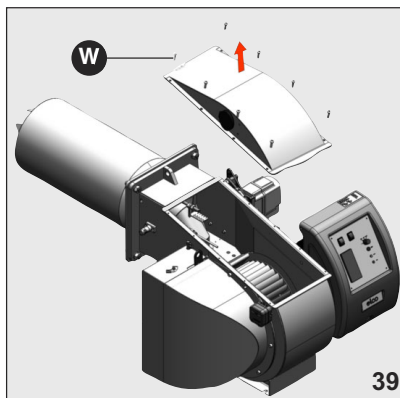

### Checking the combustion components

- Unscrew the 8 screws **W**, remove the housing cover.
- Remove the combustion components.
- Check the ignition electrodes and ignition cables, replace them if necessary (see chapter on control / maintenance, combustion components).
- Clean the deflector.
- Check adjustments and settings during installation.

### Cleaning the fan

- Disconnect the motor by unplugging it from the power supply.
- Remove the fan wheel.
- Clean the fan wheel.
- Do not use pressure media.
- Reassemble.

### Note:

To install and dismantle the fan wheel, refer to the chapter on maintenance/ fan wheel.

en

 <b>Recording commissioning data</b>					
Test		n°1	n°2	n°3	n°4
Date					
Model					
Type gas					
Gas calorific value					
Gas inlet pressure	mbar				
Adjustment gas pressure					
Volumetric gas flow rate	Nm³/h				
Burner output	min kW				
Burner output	max kW				
Flue gas temperature	C°				
Air temperature	C°				
CO <sub>2</sub>	%				
CO	ppm				
NOx	ppm				
Performance	%				
Corrective action					
Operator name					
Company					

# Servicing

## Maintenance

### Checking / installing the combustion components

#### Filter replacement

- Close the main gas shutting valve, and protect it to prevent from unintended opening.
- Vent carefully the gas pipe et check that no pressure is available.
- Loosen the screws on the multiblock cover.
- Remove the filter element and clean its housing.
- Do not use any pressurised cleaning products.
- Replace the filter element with a new element.
- Screw the cover back into place.
- Reopen the manual gate valve.
- Check it is airtight.
- Check the combustion values.

#### Cleaning the cover

- Do not use abrasive products or products containing chlorine.
- Clean the cover with water and a suitable cleaning product.
- Refit the cover.

#### Cleaning the burner body

- Do not use any cleaning product with hydrocarbon-based solvent.

#### Installing the combustion components

- Check whether the gasket is fitted and in the correct position on the gas elbow flange.
- Check the turbulator (if it is dirty or sooty, clean it).
- Check the gas nozzles (if they are clogged, dirty or damaged, replace them).
- Check the ignition transformer
- Check the electrode settings
- Check the ignition cable
- Connect the ignition lead to the electrode and to the ignition transformer.
- Connect the ionisation cable to the combustion components.
- Insert the combustion components into the flame tube, tighten the fastening screws S3, and connect the head movement connection rod S4.
- Connect the ignition lead to the ignition transformer.
- Connect the ionisation lead to the connector on the burner body.

#### Important

If the system is converted from natural gas type E to L or LL, the burner must be reset. It is necessary to modify the combustion components (kit available).

- Cleaning products based on surface active agents are allowed.



#### Important

**After every operation: check the combustion parameters and real operating condition (doors closed, cover fitted etc.). Record the results in the relevant documents.**

#### Important

**Once the pressure switches have been set, they must be protected to prevent settings from being altered. For example, this can be done by placing a spot of varnish on at least one of the screws on the equipment's protective cover. After the burner is maintained or after safety device equipment settings for the burner have been changed (e.g. pressure switches), the safety equipment for the burner must be checked to ensure it is working properly. After burner maintenance, the boiler safety chain must also be checked to ensure that it is working properly in accordance with the current specifications. This**

**check must be carried out with the operator's agreement.**

#### Checking the flue gas temperature

- Check the flue gas temperature at regular intervals.
- Clean the boiler if the flue gas temperature is more than 30°C above the value measured at the time of commissioning.
- Use a flue gas temperature gauge to make the check easier.

**Note:** To provide an example, only the scenario with burner EK-TRON 6 is shown.

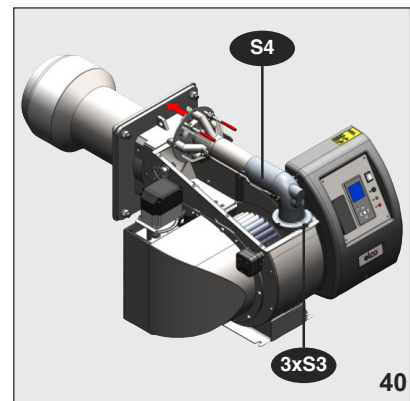

# Servicing

## Fan wheel setting

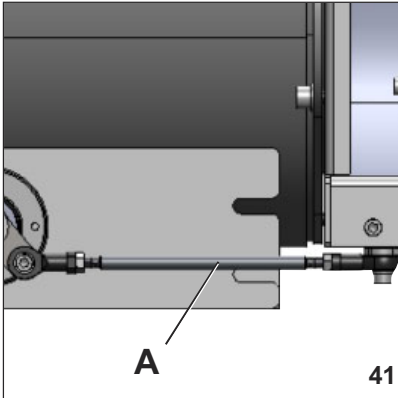

Because of its design the turbine can be fitted to the drive shaft only in a fixed position. The same position is consequently ensured every time it is assembled. There is no need for any further adjustment of the axial cover through the air conveyor.

### Access to the turbine

- Detach tie rod **A** from the lever that moves the air shutter (only mechanical version R)(fig.41).
- Remove the two tubes from the air intake while carefully marking their position (**they must not be inverted**)(fig.42).
- Loosen the screws that secure the air case and remove the latter.

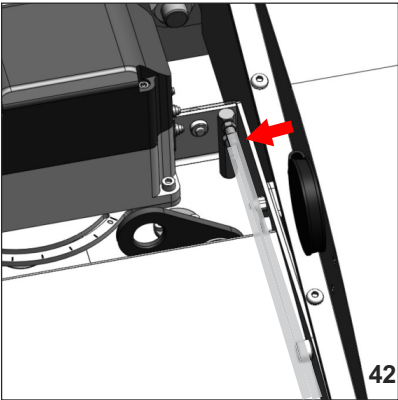

### Disassembling the turbine

- Loosen the screw (pos. **1**) and remove the washer (pos. **2**) to disassemble the turbine.
- Then separate the turbine from the shaft end with the help of an extractor and make sure it is not damaged.

### Assembling the turbine

- Before assembling, clean and degrease all the bare surfaces.
- To fit the turbine slide it as far as the axial stop on the shaft end. Fit the washer again (pos. **2**) using the screw (pos. **1**) and tighten it to 45Nm.
- Fasten the screw (pos. **1**) using LOCTITE 243. Before fitting the turbine, visually check for any damage.

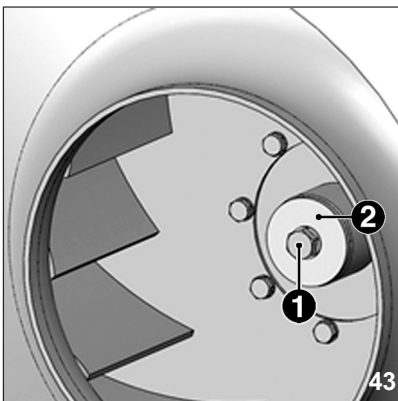

Mount the air case back on in reverse order with respect to steps listed in the “**Access to the turbine**“ paragraph, taking care not to damage the pressure switch tubes by placing them in their original position.

**To avoid any unbalance risks, do not re-use damaged turbines!**

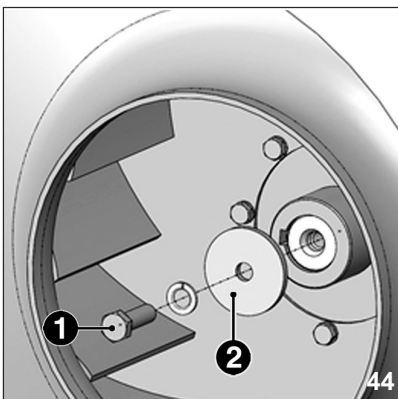

en

# Servicing

## Exhaust gas measurements

### Exhaust gas measurement

In order to ensure efficient and fault-free operation, the burner must be adjusted with reference to the specific system. The fuel combustion air compound controller, which is used to set the burner to clean combustion, is used for this. To do this, exhaust gas measurements must be carried out. To determine the efficiency and quality of combustion, the percentage of CO<sub>2</sub> or O<sub>2</sub> and the flue gases temperature must be measured. Before the test is carried out, it is essential to ensure that the boiler and/or the exhaust gas system are properly sealed.

### False air distorts the measurement

If possible, the exhaust gases should not have any residual oxygen content (O<sub>2</sub>) and/or they should contain as much carbon dioxide (CO<sub>2</sub>) as possible. In all load stages, the carbon monoxide content of the exhaust gases must be below the limit values specified in the relevant current specifications. If fuel-oil is being used, the permissible smoke

spot number in the exhaust gas must not be exceeded.

### Calculating the volumetric flow rate for gas

The combustion output (Q<sub>F</sub>) of a boiler is the amount of heat supplied by the gas in a time unit. When commissioning the system, the fuel volume flow must be set in accordance with the nominal heat output of the boiler.

### Example:

Nom. thermal output	Q <sub>N</sub>	1000 kW
Boiler efficiency	η <sub>K</sub>	0,88
Calorific value of gas	H <sub>U</sub>	9,1 kWh/m <sup>3</sup>
Gas pressure	p <sub>U</sub>	100 mbar
Barometer reading	p <sub>amb</sub>	980 mbar
Gas temperature relative	t <sub>gas</sub>	15°C
Gas temperature absolute	T	(t <sub>gas</sub> +273)
Standard atmospheric pressure	p <sub>n</sub>	1013 mbar

$$Q_F = \frac{Q_N}{\eta_K} = \frac{1000}{0,88} = 1136 \text{ kW}$$

Volumetric gas flow rate at STP:

$$V_{Bn} = \frac{Q_N}{H_U \cdot \eta_K} = \frac{1000}{9,1 \cdot 0,88} = 125 \text{ m}^3/\text{h}$$

Volumetric gas flow rate in operating condition:

$$V_{BB} = V_{Bn} \frac{T}{273} = \frac{p_n}{p_{amb} + p_u} = 125 \frac{273+15}{273} \frac{1013,25}{980+100} = 123,9 \text{ m}^3/\text{h}$$

### Relationship between O<sub>2</sub> and CO<sub>2</sub> rate for natural gas H (CO<sub>2max</sub> =11.86%)

%O <sub>2</sub>	%CO <sub>2</sub>	%O <sub>2</sub>	%CO <sub>2</sub>
0,00	11,86	3,00	10,16
0,10	11,80	3,10	10,10
0,20	11,75	3,20	10,04
0,30	11,69	3,30	9,99
0,40	11,63	3,40	9,93
0,50	11,58	3,50	9,87
0,60	11,52	3,60	9,82
0,70	11,46	3,70	9,76
0,80	11,41	3,80	9,70
0,90	11,35	3,90	9,65
1,00	11,29	4,00	9,59
1,10	11,24	4,10	9,53
1,20	11,18	4,20	9,48
1,30	11,12	4,30	9,42
1,40	11,07	4,40	9,36
1,50	11,01	4,50	9,31
1,60	10,95	4,60	9,25
1,70	10,90	4,70	9,19
1,80	10,84	4,80	9,14
1,90	10,78	4,90	9,08
2,00	10,73	5,00	9,02
2,10	10,67	5,10	8,97
2,20	10,61	5,20	8,91
2,30	10,55	5,30	8,85
2,40	10,50	5,40	8,80
2,50	10,44	5,50	8,74
2,60	10,38	5,60	8,68
2,70	10,33	5,70	8,63
2,80	10,27	5,80	8,57
2,90	10,21	5,90	8,51

### Relationship between O<sub>2</sub> and CO<sub>2</sub> rate for domestic fuel-oil (CO<sub>2max</sub> =15.40%)

%O <sub>2</sub>	%CO <sub>2</sub>	%O <sub>2</sub>	%CO <sub>2</sub>
0,00	15,40	3,00	13,19
0,10	15,33	3,10	13,12
0,20	15,25	3,20	13,04
0,30	15,18	3,30	12,97
0,40	15,11	3,40	12,89
0,50	15,03	3,50	12,82
0,60	14,96	3,60	12,75
0,70	14,88	3,70	12,67
0,80	14,81	3,80	12,60
0,90	14,74	3,90	12,53
1,00	14,66	4,00	12,45
1,10	14,59	4,10	12,38
1,20	14,52	4,20	12,31
1,30	14,44	4,30	12,23
1,40	14,37	4,40	12,16
1,50	14,29	4,50	12,08
1,60	14,22	4,60	12,01
1,70	14,15	4,70	11,94
1,80	14,07	4,80	11,86
1,90	14,00	4,90	11,79
2,00	13,93	5,00	11,72
2,10	13,85	5,10	11,64
2,20	13,78	5,20	11,57
2,30	13,71	5,30	11,49
2,40	13,63	5,40	11,42
2,50	13,56	5,50	11,35
2,60	13,48	5,60	11,27
2,70	13,41	5,70	11,20
2,80	13,34	5,80	11,13
2,90	13,26	5,90	11,05

$$O_2 = 21 \times \frac{CO_{2max} - CO_{2gem}}{CO_{2max}} = \%$$

Mean barometer readings		
	Height above sea level [m]	Mean barometer readings [mbar]
Aachen	205	991
Berlin	50	1009
Dresden	120	1000
Erfurt	315	978
Frankfurt/M.	104	1004
Hamburg	22	1011
Cologne	45	1009
Leipzig	130	998
Magdeburg	79	1005
Munich	526	955
Nuremberg	310	980
Rostock	4	1013
Stuttgart	297	984
Schwerin	59	1010
Ulm	479	960

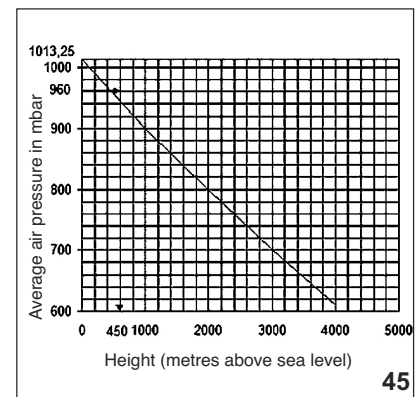

# Servicing

## Exhaust gas measurements Diagnosing and remedying faults

### Exhaust gas loss

Exhaust gas loss by way of free heat will occur as a result of the temperature difference between the fuel-air mixture entering the furnace chamber and the gases discharged. Any increase in the excess of air and the resultant higher exhaust gas volume will cause the exhaust gas loss to rise. It is calculated as follows:

$$q_A = (t_A - t_L) \times \left( \frac{A_1}{CO_2} + B \right)$$

q A = exhaust gas loss in %

t A = flue gases temperature in °C

t L = combustion air temperature in °C

CO<sub>2</sub> = carbon dioxide content in %

	Fuel-oil EL	Fuel-oil S	Natural gas	Town gas	Liquid gas
A <sub>1</sub> =	0.50	0.490	0.370	0.350	0.420
B =	0.007	0.007	0.009	0.011	0.008

Example:

Data measured in natural gas mode:

CO<sub>2</sub> content of the exhaust

gases 10.8%

Flue gases temperature 195°C

Air intake temperature 22°C

The exhaust gas loss can be calculated as follows:

$$q_{Af} = (195 - 22) \times \left( \frac{0,37}{10,8} + 0,009 \right) = 7,48\%$$

Measured values in fuel-oil operation:

CO<sub>2</sub> content of the exhaust

gases 12.8%

Flue gases temperature 195°C

Air intake temperature 22°C

The exhaust gas loss can be calculated as follows:

$$q_{Af} = (195 - 22) \times \left( \frac{0,49}{12,8} + 0,007 \right) = 7,83\%$$

**In the vent of a fault, proceed with checking the basic conditions for a proper operation of the boiler system:**

1. Is electric power available?
2. Is there any gas pressure?
3. Are the shut-off valves opened?
4. Are all control and safety devices, e.g. boiler thermostat, low water detector, limit switches, etc. properly set?

1. Ignition - ignition failure	
Cause	Remedy
Ignition electrode short circuit.	Adjust.
Wide ignition electrode spacing.	Adjust.
Dirty and wet electrodes.	Clean.
Cracked insulator.	Replace.
Defective ignition transformer.	Replace.
Defective automatic firing device.	Replace.
Burnt ignition cable.	Replace; search for cause and eliminate.
Pilot burner failure.	Adjust ignition gas pressure
Ignition gas valve does not open.	Search for cause and eliminate
Defective solenoid.	Replace.

2. Motor is not running	
Cause	Remedy
Motor protection relay and fuses.	Check and replace if required.
Air pressure switch not changed over or defective.	Check and replace if required.
Defective motor.	Replace.
Defective power contactor.	Replace contactor.
Fan motor starts but stops after 20-25 secs.	Check for solenoid leaks
Fan motor starts, but stops after about 10 secs in pre-ventilating mode.	Air pressure switch does not switch, defective : replace, clogged: clean, electrical connections: check

en

# Servicing

## Diagnosing and remedying faults Faults

4. No response to flame by Automatic firing device with flame sensor	
Cause	Remedy
Dirty flame sensor.	Clean.
Burner fails to start.	Check connection with the automatic firing device
Automatic firing device warning light on; flame fault	Unlock and search for cause
Ionisation current too weak.	Check combustion setting
Burner starts without flame formation:	Coil, detector defective, check connection
solenoid valve not opening	
Lack of gas or gas pressure too low.	Check gas pressure regulator, gas valve, gas filter. Is the equipment gas cock open?

5. Combustion components - poor combustion values heavy internal oil deposits or heavy coke deposits (fuel-oil mode)	
Cause	Remedy
Incorrect settings.	Correct settings.
Incorrect burner head	Replace
Nozzle too big or too small	Replace
Incorrect nozzle spray angle	Replace nozzle
High or low combustion air flow rate.	Readjust burner.
Furnace chamber not sufficiently ventilated.	The boiler room must be ventilated through an unlockable opening with a cross section of at least 50 % of all chimney cross sections in the furnace.
Lack of gas or gas pressure too low.	Check gas pressure regulator, gas valve, gas filter. Is the equipment gas cock open?

6. Solenoid valve fails to open	
Cause	Remedy
Defective coil.	Replace coil or valve
Defective automatic firing device.	Replace automatic firing device.
Will not close properly: dirt on sealing surfaces	Open valve; remove foreign matter; replace valve if required.

### Smell of gas, danger of gas

- Shut down the burner
- Close the gas shut-off valve
- Keep away fire and naked flames
- Switch off the emergency switch
- Ensure there is adequate ventilation
- Notify the gas supplier and customer services.
- **According to DIN 4788, components with technical safety-related functions may not be repaired. On the other hand, they may be replaced by original parts or parts of equal quality.**

### How to proceed in case of hazards

- Switch off the emergency switch
- Close fuel valves
- If there is a smell of gas, notify the gas supply company.
- Use suitable extinguishing equipment, e.g. fire extinguisher in acc. with DIN 14 406, fire class B,C.
- Servicing work on pressure switches, automatic actuators, limiters and automatic firing devices or other safety devices may only be carried out by the relevant manufacturer or by

service engineers authorised to service the individual items of equipment on their behalf.

- If third parties work on the system, our obligations under warranty become void.

### If system faults occur, proceed with checking the basic conditions for proper operation of the system. Make a check for the following:

1. Is fuel available, is it flowing through the lines and is the supply pressure adequate?
2. Is power being supplied to the system?
3. Is all control and safety equipment such as temperature controller, safety limiter, water failure cut-out, electrical limit switches, etc., functioning properly and correctly adjusted? If it is found that none of the above reasons for the fault applies, the burner functions must be thoroughly checked.

### Prevailing conditions:

The burner will be found to be out of

operation and in faulty and interlocked position. Proceed with searching for the cause of the fault and eliminate it. Unlock the automatic firing device by pressing the fault eliminate key and start the burner. The start-up program will be initiated and should be carefully monitored. The possible cause of the fault may be quickly found by referring to the fault indicator on the automatic firing device and watching the start-up and operating program.

## Troubleshooting instructions

### 16 Error code list

Error code	Clear text	Possible causes
<b>7-Segment</b>		
Loc 2	No establishment of flame at the end of safety time	<ul style="list-style-type: none"> <li>- Faulty or soiled fuel valves</li> <li>- Faulty or soiled flame detector</li> <li>- Poor adjustment of burner, no fuel</li> <li>- Faulty ignition equipment</li> </ul>
Loc 3	Air pressure faulty (air pressure switch welded in no-load position, decrease to specified time (air pressure switch flame-on response time)	Air pressure switch faulty <ul style="list-style-type: none"> <li>- Loss of air pressure signal after specified time</li> <li>- Air pressure switch has welded in no-load position</li> </ul>
Loc 4	Extraneous light	Extraneous light during burner startup
Loc 5	Air pressure faulty, air pressure switch welded in working position	Time supervision air pressure switch <ul style="list-style-type: none"> <li>- Air pressure switch has welded in working position</li> </ul>
Loc 6	Fault of actuator	<ul style="list-style-type: none"> <li>- Actuator faulty or blocked</li> <li>- Faulty connection</li> <li>- Wrong adjustment</li> </ul>
Loc 7	Loss of flame	Too many losses of flame during operation (limitation of repetitions) <ul style="list-style-type: none"> <li>- Faulty or soiled fuel valves</li> <li>- Faulty or soiled flame detector</li> <li>- Poor adjustment of burner</li> </ul>
Loc 10	Error not relatable (application), internal error	Wiring error or internal error, output contacts, other faults
Loc 12	Valve proving	Fuel valve 1 leaking
Loc 13	Valve proving	Fuel valve 2 leaking
Loc 22	Safety loop open	<ul style="list-style-type: none"> <li>- Gas pressure switch-max open</li> <li>- Safety limit thermostat cut out</li> </ul>
Loc 60	Analog power source 4...20 mA, I<4 mA	Wire breakage
Loc 138	Restore process successful	Restore process successful
Loc 139	No program module detected	No program module plugged in
Loc 167	Manual locking	Manual locking
Loc 206	AZL2... incompatible	Use the latest version
rSt Er1	Error in compatibility program module to basic unit during restore process	<ul style="list-style-type: none"> <li>- Program sequence of program module does not match the basic unit</li> </ul>
rSt Er2	Error in compatibility program module to basic unit during restore process	<ul style="list-style-type: none"> <li>- Hardware of basic unit does not match the program module</li> </ul>
rSt Er3	Error during restore process	<ul style="list-style-type: none"> <li>- Program module faulty</li> <li>- Program module removed during restore process</li> </ul>
bAC Er3	Fault of compatibility program module to basic unit during backup process	Program sequence of program module does not match the basic unit
Err PrC	Fault of program module	<ul style="list-style-type: none"> <li>- Error in data content of program module</li> <li>- No program module fitted</li> </ul>

en

---

A series of horizontal lines for writing, consisting of a solid top line and a dotted bottom line for each row.

---

Lined writing area with horizontal lines.

en

# elco

---



[www.elco-burners.com](http://www.elco-burners.com)



[www.elco.net](http://www.elco.net)

Hergestellt in der EU. Fabriqué en EU. Fabricato in EU.  
Angaben ohne Gewähr. Document non contractuel. Documento non contrattuale.

09/09/2022 - Art. Nr. 420011248600